



## Procal 5000 UV Emissions Analyser

- ~ In-situ, multi-component UV emissions analyser
- ~ Low cost through-life ownership
- ~ 1024-bit spectrum resolution

## Instrument Overview

Procal 5000 is an ultra-violet (UV), continuous emission monitoring analyser, designed for in situ analysis of gas-phase emission components. Using absorption spectroscopy, Procal 5000 stores and analyses the full UV spectrum and calculates the gas emission concentrations.

A typical system comprises an in situ analyser, an integral calibration function and a Control Unit. Procal 5000 uses the

reflective beam principal to directly measure process gas as it enters the in situ sample cell. Unlike higher maintenance extractive systems, Procal's patented, sintered metal technology removes the need for gas filtering or sample conditioning. Maintenance is minimised by an integral zero and calibration point gas capability and frequent calibration checks which can be undertaken without intervention, enabling automated legislative compliance.

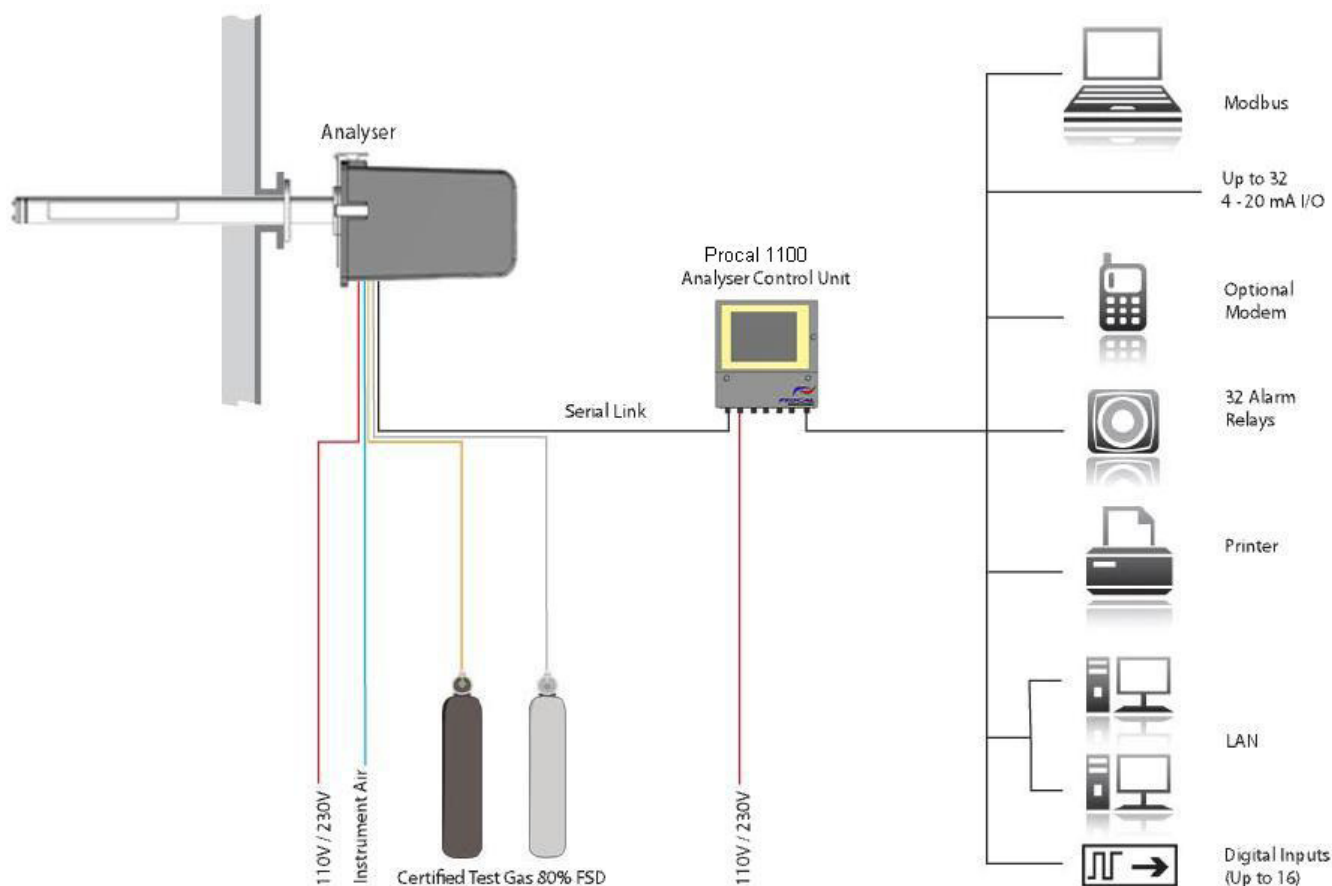

## Principles of Operation

**Analyser:** The Procal 5000 analyser uses a single beam of UV light from a long-life deuterium arc lamp. The beam is split and directed into a folded beam cell assembly before returning to fall on to a 1024 bit diode receiver array. A narrow region of the spectrum is measured by each diode and the spectrum is logged as a vector intensity enabling gas concentrations to be calculated. Up to six gas-phase component concentrations can be monitored simultaneously. Uniquely, the operation, zeroing and calibration are "fully challenged" in that all operating modes use the same optical path and system components.

**Applications:** The Procal 5000 analyser has been in service for over 15 years with continual product improvement to match ever-tightening legislative requirements. Over 100 Procal 5000 units are in operation worldwide - refer to our industry data sheets or visit [www.procal.com](http://www.procal.com) for typical applications and associated measurement ranges.

## Optional Components

Optional accessories are available to extend the analyser's capability in cases of extreme process or ambient variations. Typical examples would be a probe heater to ensure the in situ gas cell operates above process gas dew point, a gas flow bypass for high thermal stress applications and a head cooler for operation in high ambient temperature conditions. Further details of these and many other accessories are available at [www.procal.com](http://www.procal.com) or on the accessories data sheet.

## Features

Multi-component gas analysis  
Direct in situ measurements

Automatic signal verification and recalibration  
Oxygen or CO<sub>2</sub> measurement normalisation

Flange mounted analyser  
Low maintenance

## Benefits

Each Procal 5000 can monitor multiple gas concentrations.  
No requirement for high cost, high maintenance sample handling system or sample conditioning.  
No operator intervention during routine use.  
Report measurement corrected to normalised O<sub>2</sub> or CO<sub>2</sub> reference conditions  
Reduced cost and simple of installation  
Reduced cost of through life ownership

## Monitoring Range

Gases measured: Series of gas concentrations as determined by the application

Ranges (minimum):

NO	0-20ppm / 26mg/Nm <sup>3</sup>	CL <sub>2</sub>	0-25ppm / 80mg/Nm <sup>3</sup>
NO <sub>2</sub>	0-20ppm / 41mg/Nm <sup>3</sup>	O <sub>3</sub>	0-1ppm / 2mg/Nm <sup>3</sup>
SO <sub>2</sub>	0-20ppm / 60mg/Nm <sup>3</sup>	H <sub>2</sub> S	0-20ppm / 30mg/Nm <sup>3</sup>
NH <sub>3</sub>	0-25ppm / 20mg/Nm <sup>3</sup>	Hg	0-2ppb / 20µg/Nm <sup>3</sup>

Other gases on application.

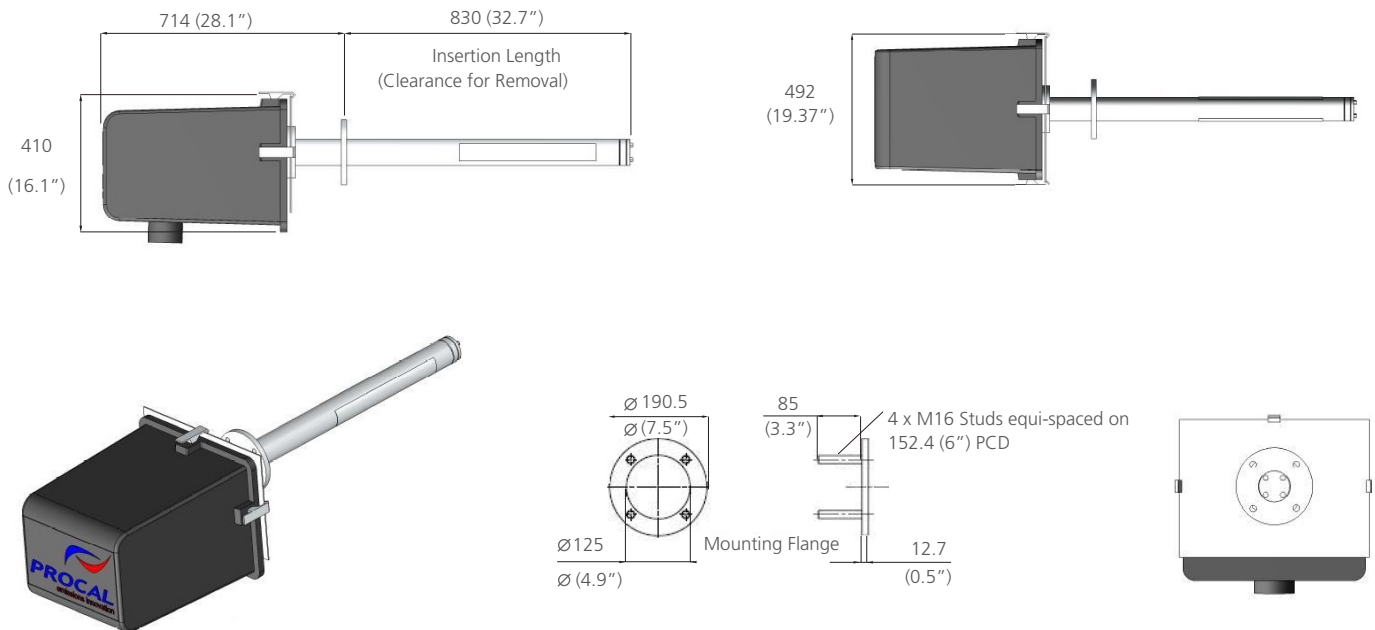

## Control Unit Options

### Analyser Control Unit - Procal 1000 range

The Procal 1000 data logging and control system can be either stand-alone or Microsoft Windows based. The system is capable of controlling up to six, widely dispersed, Procal analysers of any design. The Procal 1000 range is also designed to accept signal I/O from other instruments in the process to provide a single CEMS data hub. The Procal 1000 system displays gas concentrations and third party analyser I/O along with information on sample conditions, diagnostic data and trends. The information can also be made available to external systems in a variety of industry standard data protocols.



## Specifications & Installation

Principle of operation:	Ultra-violet absorption full spectrum method.
Spectral range:	180nm to 400nm
Ultra-violet source:	Extended life deuterium lamp.(typically 7000 hrs).
Ultra-violet detector:	Miniature 1024 bit photo diode array
Sample path length:	1 metre. (Other lengths on application.)
Cross-sensitivity:	Minimal due to full spectrum principle and advanced algorithms in the processor software.
Pressure compensation:	To allow for atmospheric/stack pressure variation
Accuracy:	Typically $\pm 2\%$ of full scale concentration but dependent on application
Response time:	Application dependent but typically 120 seconds to T90
Calibration Requirements:	Supplied pre-calibrated. Short term drift of less than the quoted accuracy is removed by zero calibration, carried out automatically, typically every 24 hours depending on application.
Enclosure:	Aluminium alloy casting with high protection finish, sealed to IP65 NEMA 4X. Outer GRP weather protection
Operating environment	-20°C to +45°C (-4°F to 113°F). Ducted air provision for extreme temperatures. Sample temperatures up to 400°C (750°F). (higher temperature on application)
Materials in contact with sample:	Calcium fluoride, glass, 316 stainless steel, graphite and fused silica.
Services required:	90-250V 80VA required for lamp PSU, head cooler fan (application dependent) and electronics. Instrument air for the analyser void purge, autozero and sample cell protection, controlled by the Procal 5000. Pressure 2.5-3 barg; flow rate 1litre/min constant, regulator takes up to 10 bar but set to 2 barg to give correct flows as Autozero unit flow is pre-set for intake of 2 bar.
Mounting flange:	3" 150lb (note this is a special flange part number 4-1114)
Weight:	35kg (77.2lb)
Dimensions:	1544mm (60.78") x 492mm (19.37") x 410mm (16.14").

## Accreditations

### Continuous Emissions Monitoring CEM - US EPA 40 CFR part 60 & 75

The Procal 5000 system is designed to meet the requirements of both customers and environmental authorities worldwide. The system enables rapid upgrades with regard to measuring range, presentation and reporting format, thus ensuring compliance with reporting criteria such as US EPA 40 CFR part 60 & 75 legislation. The system calculates errors due to drift in Zero & Span Calibration before correction.



**Kittiwake Procal Ltd**  
5 Maxwell Road  
Peterborough  
PE2 7HU  
United Kingdom

Tel: +44 (0) 1733 232495  
Fax: +44 (0) 1733 235255  
sales@procal.com  
www.procal.com