

Multiparameter analyzers with
Fieldbus technology. For analog,
digital and Memosens sensors

Stratos





Stratos

Multi-Talents with Bus Communication



With their exceptional functionality, reliability and application-oriented design, Stratos analyzers are well-established in the entire chemical industry, in process and power plant engineering and in the pharmaceutical and biotechnology industries.

The models that are equipped with proven bus technologies can be perfectly integrated in new and existing host systems (PROFIBUS: PA profile 3.02 and FOUNDATION Fieldbus ITK 6.1.1).

All settings can be configured directly on the device or via Enhanced EDD or DTM using standardized engineering tools. Compatibility and interoperability tests ensure that the Stratos bus devices can be integrated in all standard automation systems.

Process data as well as the current level of sensor wear and information for predictive maintenance (CIP/SIP) are reliably communicated via the bus systems. The devices comply with NAMUR NE 107 and provide the corresponding proactive diagnostic features.

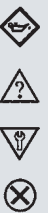

IP 67

NEMA 4X





*Memosens sensors:
pH/ORP,
conductivity,
oxygen*



Digital toroidal conductivity sensor



*Analog sensors:
pH/ORP,
conductivity,
oxygen*



Digital, optical oxygen sensor (Stratos Evo PROFIBUS)



Stratos Bus Devices

Multiparameter Devices for Measuring pH/ORP, Conductivity or Oxygen

Simple Switchover to Different Process Variables

Easy connection of analog, digital and Memosens sensors.

For measurements with analog sensors, the devices can be adapted to the desired process variable by using different measuring modules.

Stratos Evo PROFIBUS provides an integrated HighPower sensor supply to enable the operation of optical oxygen sensors which are immune to interference. It can also supply power to external 2-wire transmitters – such as pressure or flow transmitters.

Digital Platform

The digital functionality eliminates a large number of interferences which can occur with analog devices.

The use of sensor cables with a length of up to 100 m and the advanced diagnostics options are just two of the advantages provided by digital technology.

Stratos

The Facts

- Multiparameter analyzers with Fieldbus communication
- Process variable selectable on the device: pH/ORP, conductivity or oxygen
- For analog and digital sensors as well as for contactless digital Memosens sensors
- Plug-in modules for operation with conventional analog sensors
- Parallel transmission of up to 8 measured values
- Monitoring of conductivity measurement according to USP <645>
- Pressure compensation or temperature can be fed through the bus
- Digital sensor information (serial number, sensor TAG, reference number, CIP/SIP cycles, wear, remaining lifetime, operating time)
- Adaptive cal timer
- Bus-controllable contacts (Stratos Evo PROFIBUS DP)
- Signaling operating states by a multi-color backlit display
- Protective pane made of safety glass
- Device status transmission acc. to NAMUR NE 107
- Logbook (AuditTrail); 100 entries
- Extremely robust, UV-resistant molded enclosure (IP 67 / NEMA 4X)



White:
Measuring mode



Red blinking:
Alarm, error



Orange:
HOLD mode



Magenta:
Maintenance request



Turquoise:
Diagnostics



Green:
Info texts

Device Status at a Glance

The Stratos bus devices enable intuitive operation with color-coded user guidance. The high-contrast widescreen display indicates the respective operating states in six different colors: Normal measuring mode is backlit in white while information mode displays are illuminated in green. The diagnostics menu, maintenance request and the hold mode are each indicated by unique colors. The alarm status is indicated in a vibrant red, a flashing red display is a sign of impermissible entries or incorrect passcodes. Scrolling plain text messages and self-explanatory icons simplify operation.



The device status (as per NAMUR NE 107) is transmitted via the bus:

- maintenance request
- out of specification
- function check
- failure

Maintenance work
when using
Memosens sensors



Maintenance work
when using
conventional sensors



Memosens

Interference-Free Coupling

The Memosens inductive sensor connector system transfers both energy and data without contact between electrochemical sensors and analyzers.

Pre-Calibrated Sensors

By using pre-calibrated sensors, Memosens ensures maximum availability and lower maintenance requirements at the point of measurement.

Intelligent Diagnostics

Memosens allows saving and analyzing process-related data directly in the sensor.

Memosens.

The Benefits at a Glance:

- Plug & Measure – Sensor replacement in seconds with pre-calibrated sensors
- Simple and safe plugging with bayonet coupling
- Contactless, digital data transfer
- All key data available in the sensor
- Longer sensor service life
- Error-free measurements, even in the toughest conditions
- Just one cable system for all sensors
- Measured values not influenced by excessively long cables

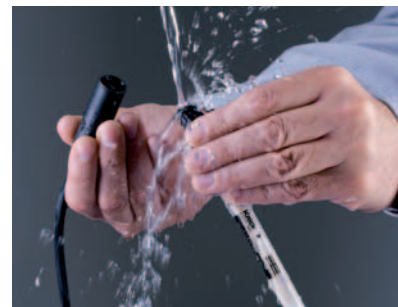

www.knick.de/memosens

engl. Link????!!!



Stratos

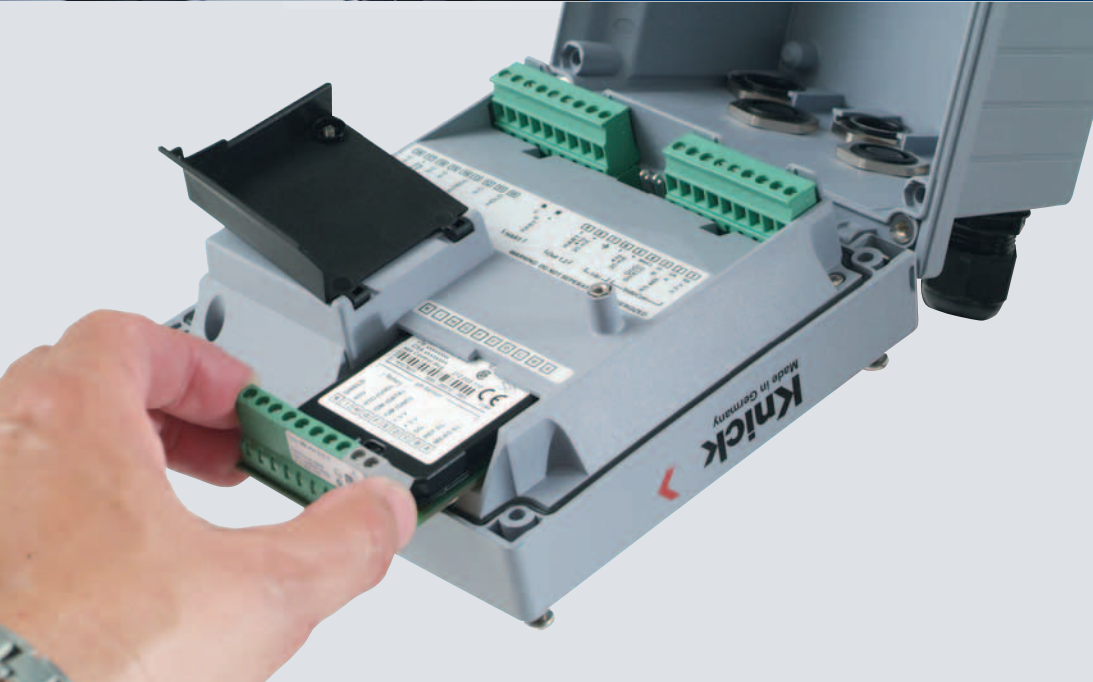

3-year warranty!

Mounting

Stratos devices are suitable for wall, pipe or panel mounting. The rear unit can be pre-assembled; all parts are easily accessible thanks to the large terminal compartment.

Measuring Modules for Operation with Analog Sensors

By simply plugging in a measuring module, the Stratos bus devices can be extended to work with analog sensors.

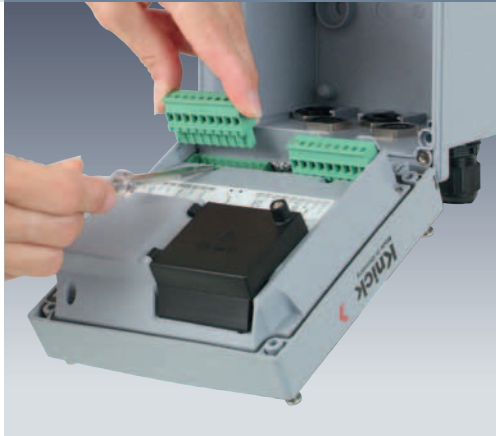

Pipe mounting



Panel mounting



Protective hood

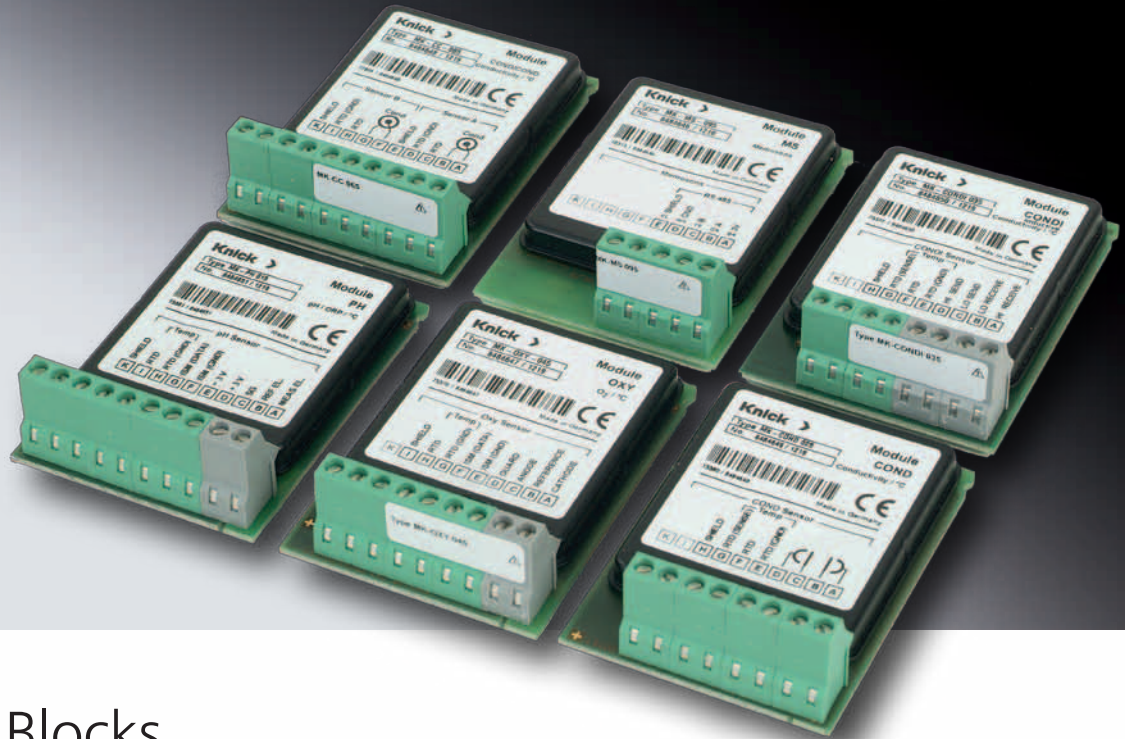

Function Blocks

Overview of the data to be transmitted depending on the process variable.*

F Block	PH	OXY	COND	CONDI	CC
AI 1	pH value	DO saturation, air	Conductivity	Conductivity	Conductivity 1
AI 2	mV value	DO concentration	Resistivity	Resistivity	Conductivity 2
AI 3	Glass impedance	Glass V concentration	Concentration	Concentration	Temperature 1
AI 4	Temperature	Temperature	Temperature	Temperature	Temperature 2
AI 5	Cal timer	Cal timer	Salinity	Salinity	pH value
AI 6	Wear	Wear	TDS	TDS	Compensation
AI 7	Flow	Flow	Flow	Flow	Flow
AI 8	Zero, slope, sensor operating time	Zero, slope, sensor operating time	Cell constant, sensor operating time	Cell constant, sensor operating time	
AO 1	Temperatur	Druck	Temperatur	Temperatur	
DI 1			USP		
DO1**	Relais 1	Relais 1	Relais 1	Relais 1	Relais 1
DO2**	Relais 2	Relais 2	Relais 2	Relais 2	Relais 2

* Typical assignments of process variables

** PROFIBUS DP only (Stratos A451N)



Stratos



Block Structure PROFIBUS DP

Typical Wiring PROFIBUS DP

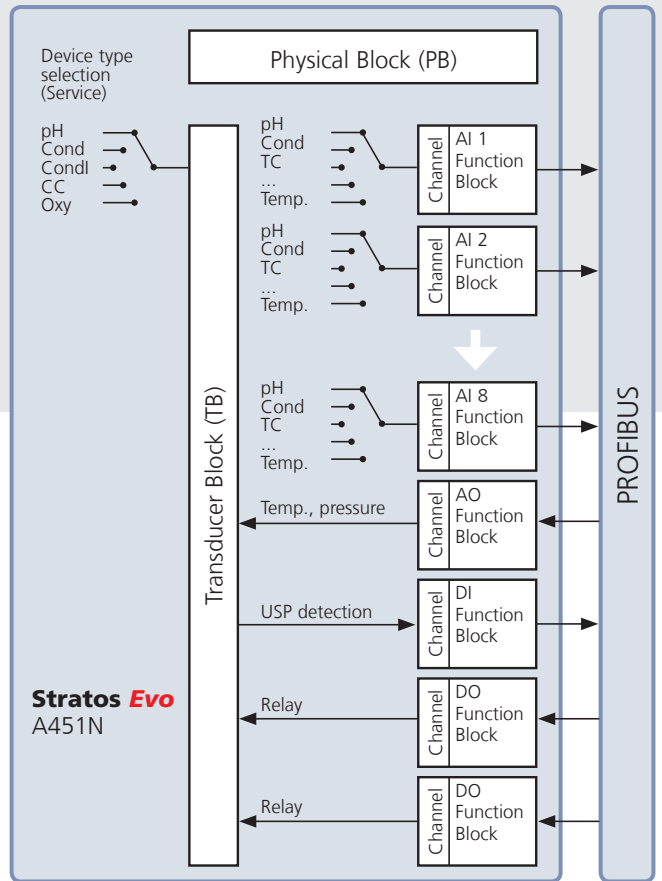
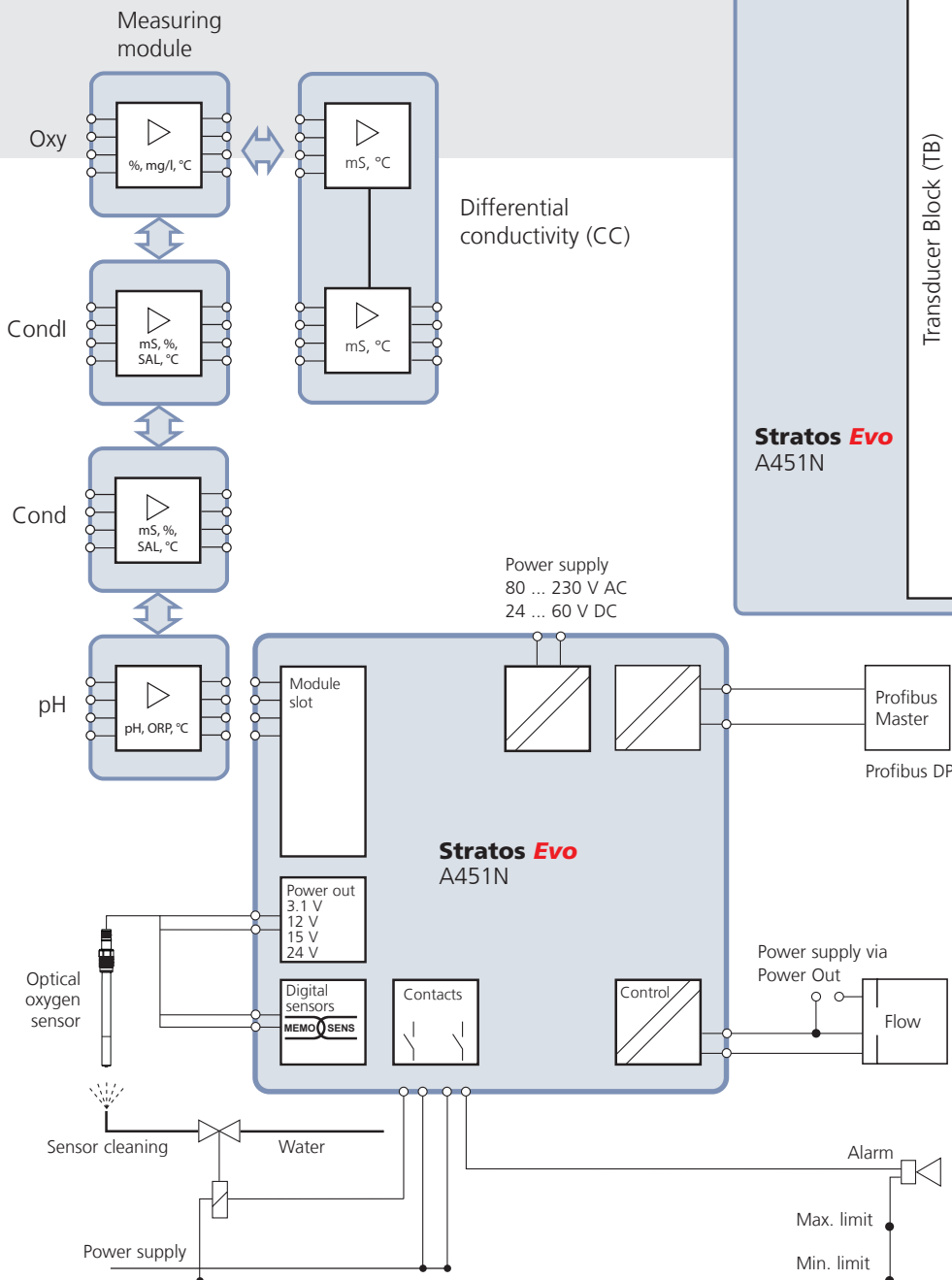



Block Structure PROFIBUS PA

Typical Wiring PROFIBUS PA

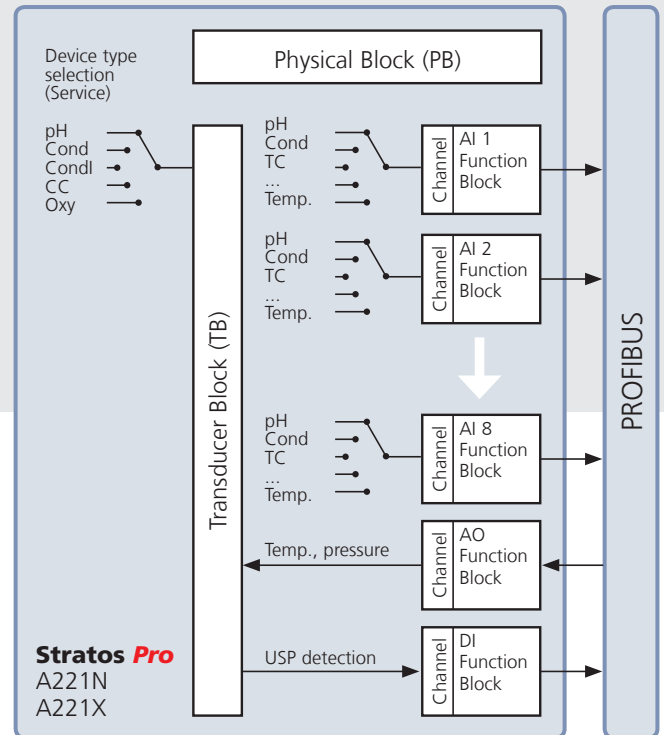
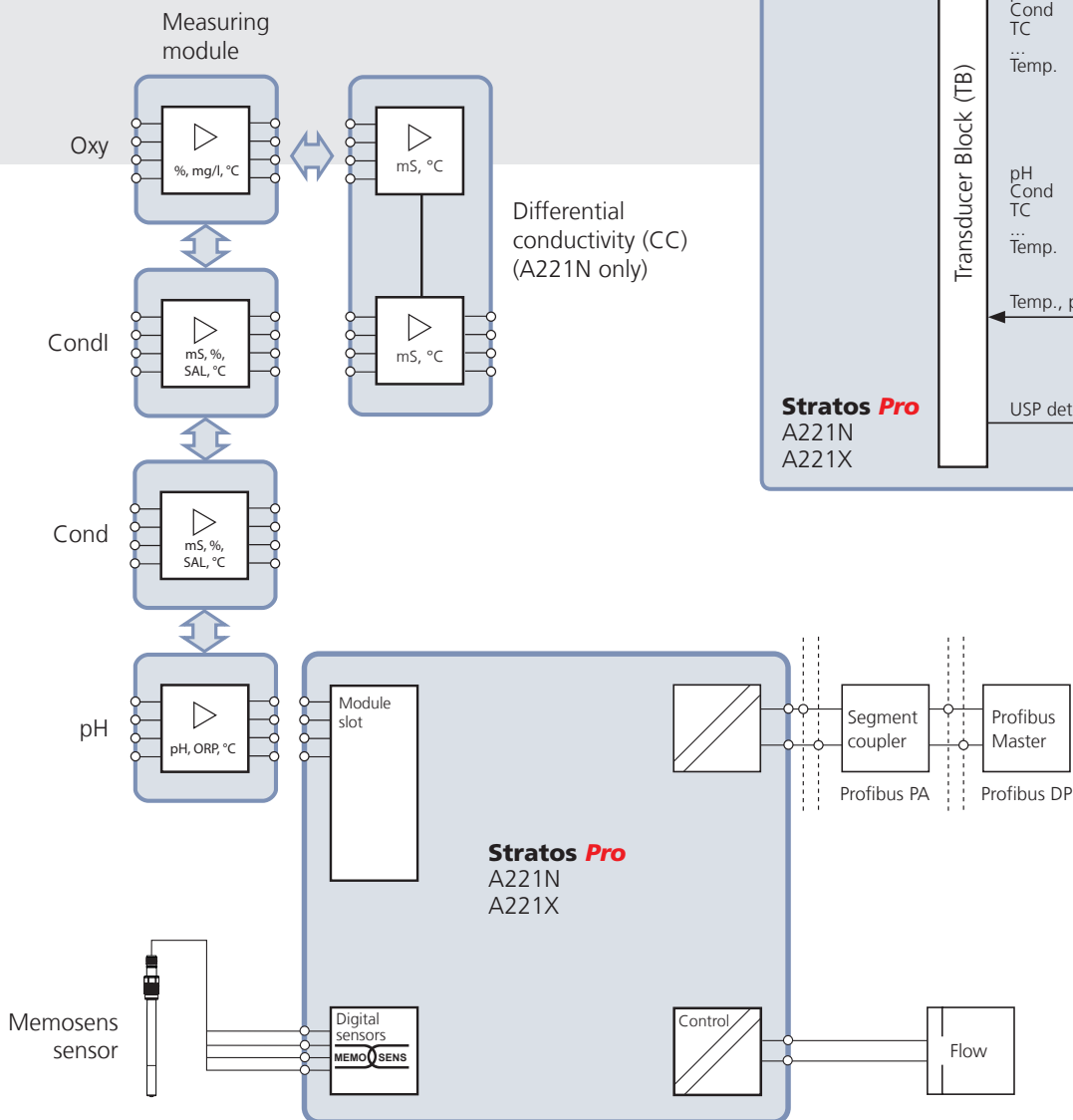



Stratos



Fieldbus
Foundation

Block Structure FOUNDATION Fieldbus FF

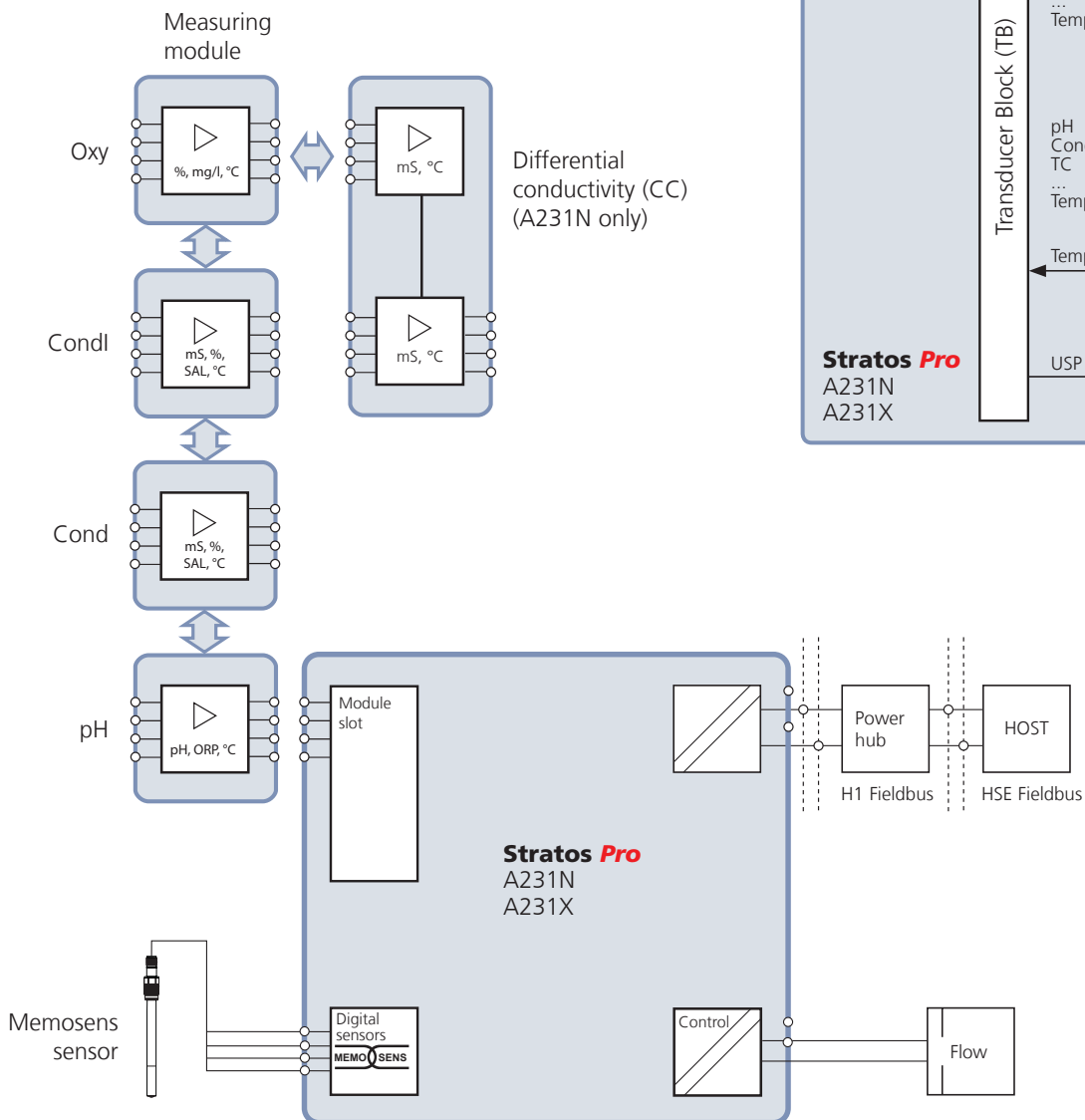

Block Structure FOUNDATION Fieldbus FF

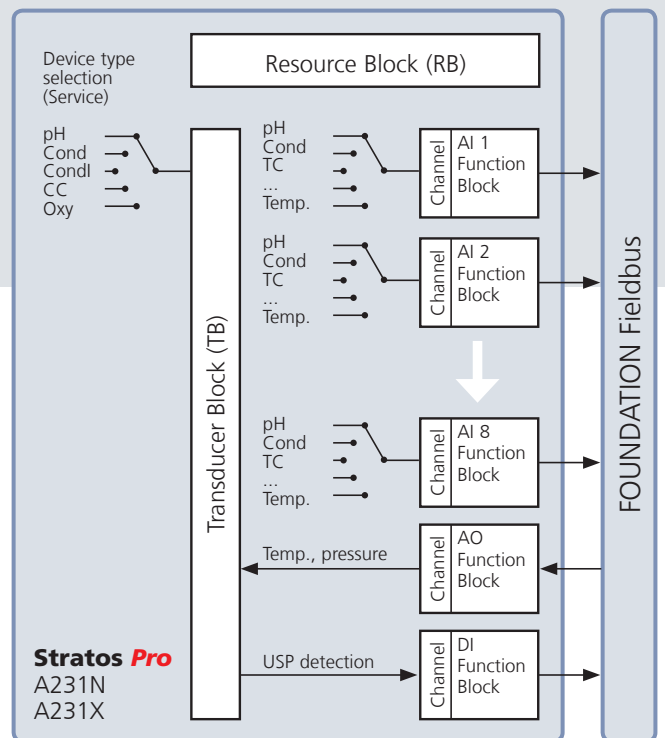

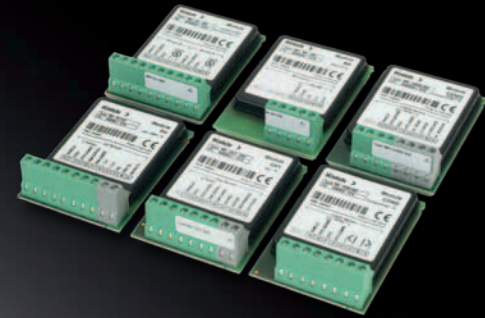

Lieferprogramm

Stratos Evo DP	Order No.
Profibus DP	A451N
Digital basic device	
Non-Ex	
Multiparameter	

Analog Measuring Modules	
pH-/ORP module	MK-PH 015N
COND module	MK-COND 025N
CONDI module	MK-CONDI 035N
OXY module	MK-OXY 045N
COND/COND module	MK-CC 065N

Accessories	Order No.
Pipe-mount kit	ZU 0274
Panel-mount kit	ZU 0738
Protective hood	ZU 0737

Stratos Pro PA	Order No.
Profibus PA	A221N
Digital basic device	
Non-Ex	
Multiparameter	

Analog Measuring Modules	
pH-/ORP module	MK-PH 015N
COND module	MK-COND 025N
CONDI module	MK-CONDI 035N
OXY module	MK-OXY 045N
COND/COND module	MK-CC 065N

Stratos Pro PA Ex	Order No.
Profibus PA	A221X
Digital basic device	
Ex	
Multiparameter	

Analog Measuring Modules Ex	
pH-/ORP module	MK-PH 015X
COND module	MK-COND 025X
CONDI module	MK-CONDI 035X
OXY module	MK-OXY 045X

Accessories	Order No.
Pipe-mount kit	ZU 0274
Panel-mount kit	ZU 0738
Protective hood	ZU 0737

Stratos Pro FF	Order No.
FOUNDATION Fieldbus	A231N
Digital basic device	
Non-Ex	
Multiparameter	

Analog Measuring Modules	
pH-/ORP module	MK-PH 015N
COND module	MK-COND 025N
CONDI module	MK-CONDI 035N
OXY module	MK-OXY 045N
COND/COND module	MK-CC 065N

Stratos Pro FF Ex	Order No.
FOUNDATION Fieldbus	A231X
Digital basic device	
Ex	
Multiparameter	

Analog Measuring Modules Ex	
pH-/ORP module	MK-PH 015X
COND module	MK-COND 025X
CONDI module	MK-CONDI 035X
OXY module	MK-OXY 045X

Accessories	Order No.
Pipe-mount kit	ZU 0274
Panel-mount kit	ZU 0738
Protective hood	ZU 0737

**Schreibweise:
»Multiparameter«
im engl. auch so???**

Stratos

The Art of Expertise

Stratos *Evo*

4-wire devices, analog,
digital and Memosens,
Profibus DP

Stratos *Pro*

2-wire devices, analog,
digital and Memosens,
Profibus PA and Foundation FIELDBUS

Stratos *MS*

4-wire devices, digital
and Memosens

Stratos *Eco*

4-wire devices, analog

im engl. Manuskript
stand hier nochmal
Stratos Evo. Korrigiert

Knick

**Elektronische Messgeräte
GmbH & Co. KG**

Beuckestraße 22, 14163 Berlin,
Germany

Phone: +49 30 801 91 - 0

Fax: +49 30 801 91 - 200

knick@knick.de · www.knick.de