

Passionate about Particulate



PCME View 580

DYNAMIC CAPACITY™
INSIDE

Particulate

Measurement

Systems

Particulate CEM



*shown with optional external keypad

- Reliable monitoring of dust concentration emissions from industrial boiler stacks and electrostatic filters
- In-built continuous compensation for dust on lenses due to Dynamic Opacity ratiometric Opacity measurement principle
- Quick access to optics for easy cleaning or inspection
- Improved performance over previous models with inbuilt Quality Assurance Features



Certificate No: 9389

applications

System Description and Product Range

The PCME View 580 is suitable for monitoring particle emissions from combustion boilers and stacks controlled by electrostatic precipitators, with high levels of reliability and robustness. The instrument comprises transmitter and receiver modules mounted on opposite side of the stack using a unique Ratiometric Dynamic Opacity algorithm to overcome contamination which is catastrophic to the performance of traditional opacity systems. Mains power and a choice of user outputs are wired directly to the receiver avoiding the need for separate remote control units.



Principles of Operation



The PCME View 580 continuous particulate monitor uses the *Dynamic Opacity™* Ratiometric opacity technology principle. This technique monitors the variation in the amount of received light from the light beam transmitted across the stack. The variation derives from the temporal distribution of particulate which attenuates the light beam. The PCME View 580 calculates the dynamic response (ratio of light variation to light intensity or obscuration). This method has the added benefit that the measurement is unaffected by lens contamination. The instrument response, which is proportional to dust concentration and can also be calibrated to read in mg/m^3 by reference to an Iso-kinetic sample (mass gravimetric technique).

Simple Instrument Maintenance and Installation

The PCME View 580 includes automatic electronic zero and span checks to give increased quality assurance that the instrument is measuring correctly. In addition, the Ratiometric Dynamic Opacity algorithm is highly resistant to dust contamination and the instrument's automatic light check provides an alarm should light levels fall to below 10% transmission, indicating the need to clean the optical surfaces.

The instrument has inherent low cost of ownership due to its measurement algorithm, however, should maintenance be necessary, easy access for cleaning is provided to all windows and mechanical parts which might come into contact with the flue gas through a simple disconnect of the optics. Blower systems are not required to keep optics clean, however, instrument air is recommended.

Lens condition	Light intensity	Variation	Scintillation
100% transmission	1	x	$x/1$
90% transmission	0.91	0.9x	$0.9x/0.91 = x/1$
50% transmission	0.51	0.5x	$0.5x/0.51 = x/1$

The transmitter and receiver do not require elaborate alignment. Simply mount on opposite sides of the stack in a way to give direct line of site between the two sensor heads.

The instrument is designed for use as a stand alone dust monitor or simple integration into a CEMs system. There is no need for a separate control unit with all user interface and external connections (mains power, relays, 4-20mA) provided directly in the sensor. The instrument may be set up by the display/keypad in the sensor or by remote PC software (optional)

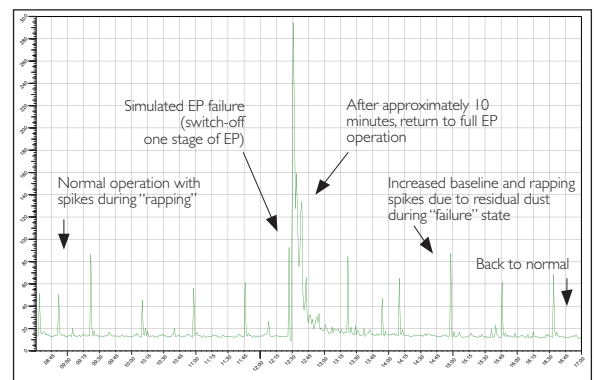

Emissions from electrostatic precipitator (during rapping cycle)

specifications

User selectable added value options

Monitoring range and application limits	
Stack size (flange to flange)	1 to 10m
Stack gas temperature	Standard Up to 250°C Option Up to 400°C
Humidity	Up to 90% non condensing
Velocity	Normal plant load (3m/s minimum)
Dust measurement range	< 10 to 10,000mg/m ³ (application dependent)
Response time	< 10 sec, 95% change (user defined)
Ambient light rejection	Modulated LED (non-visible spectrum)



The instrument is provided with internal electronic self-checks as standard. For added benefits, these may optionally be upgraded from manual to automatic control.

Specifications	Receiver/User Interface	Transmitter
Ambient temperature (for stack temperature see above)	-25°C to 55°C	-25°C to 55°C
Stack connection	DN40 PN6	DN40 PN6
External dimensions (mm)	200W x 190H x 200D (from flange)	200W x 190H x 200D (from flange)
Weight (kg)	3.9	3.5
Enclosure rating	IP-65 (with hinged lid closed)	IP-65 (with hinged lid closed)
Power requirements	110/230VAC 50/60Hz (32mA) or 24VDC (300mA)	Supplied by receiver
Outputs	Isolated 4-20mA (500 ohm) Alarm 1: Fault SPST 1A@24VDC Alarm 2: Emission alarm SPST 1A@24VDC (fail safe connected) RS-232 (Modbus) output - option RS-485 (Modbus) - option	N/A
External LED x3	Indicates power, fault and emission alarm	
User set up	4 digit display and Set-up keys accessible on opening hinged lid (option for external keys)	N/A
Cable entries	3 x M20 gland/conduit entries	1 x M20 gland/conduit entries
Connecting cable between receiver and transmitter	Supplied with 10m of cable (8 core, 7 x .22mm screened, PVC insulated, over all diameter 6.3mm)	
Air purge connection	1/4" BSP	1/4" BSP
Anti fouling connection (for high humidity/high dust applications)	Optional extra	Optional extra

Optional PC Software

PC connects to the receiver via optional RS232 or RS485 input connector (RS485 optional)



PC software	Purpose
Configuration	For instrument configuration by PC
PC view	For viewing emissions on PC

specifications

Physical Dimensions & Order Codes

PCME View 580 (back views)

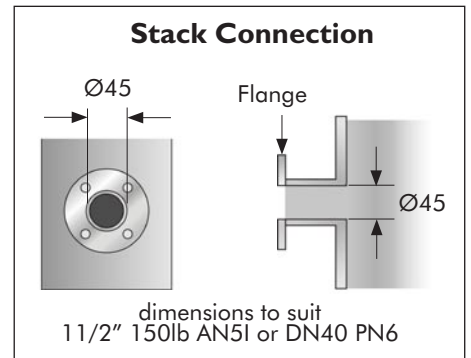
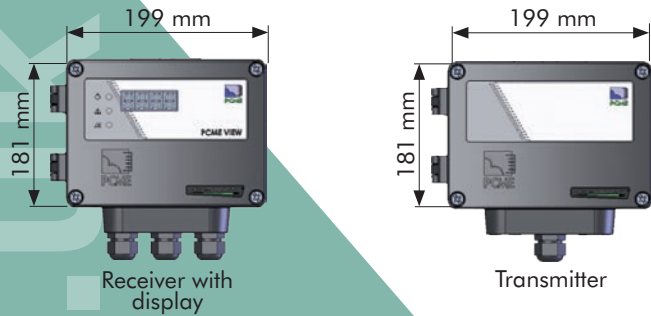

Sensor Options (side views)

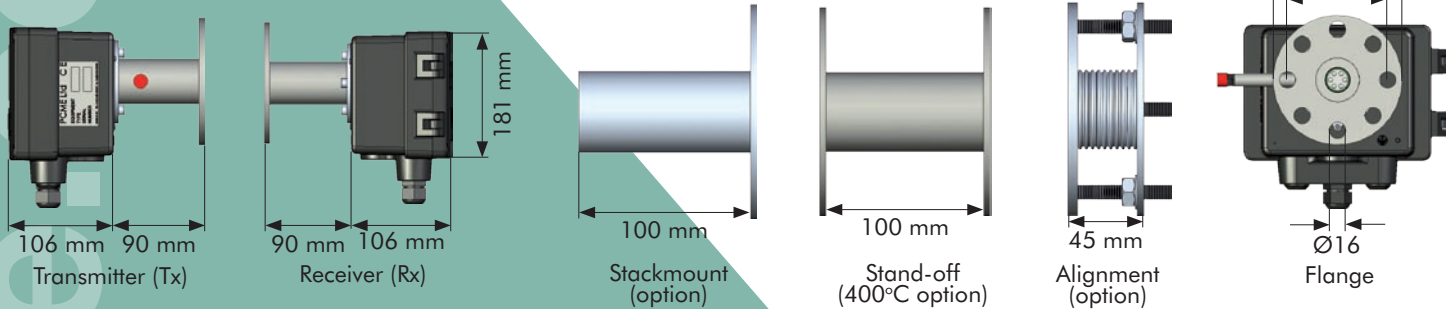

Order Code

PCME View 580 - I 2 3 4 5 - B E F G H I

Example PCME View 580 -

I	2	3	4	5	A	B	C	D	E	F	G	H	I	J
250C	0	ALIGN	0	REG	CC	AUTO	SF	0	AC	485	232	FLY	EK	ED

Mechanical Features

1	Stack Temperature	250°C 400°C (provide stand-off)	Standard Option	250C 400C
2	Anti-fouling fittings	None Pair	Standard Option	0 AF
3	Alignment fitting	None I set (Tx)	Standard Option	0 ALIGN
4	Stack Mounting flanges	None Pair	Standard Option	0 SM
5	Air Filter/Regulator	None Filter + regulator assembly	Standard Option	0 REG

Electrical Options

A	Contamination Check optics	Included	Standard	CC
B	Electronic Self-checks	Manual initiated Automatic	Standard Option	MAN AUTO
C	Scaling Method	Scaling factor	Standard	SF
D	ATEX category	None	Standard	0
E	Power option	115/230V AC 24V DC	Standard Option	AC 24DC
F	RS485 Data output	Not included RS485 included	Standard Option	0 485
G	RS232 Data output	Not included RS232 included	Standard Option	0 232
H	External Connector for RS232	Internal connector External connector	Standard Option	0 FLY
I	Keypad	Internal keypad External keypad	Standard Option	IK EK
J	Display	Externally viewable	Standard	ED

About PCME Ltd

As a progressive environmental Company, PCME specialises in particulate measurement for industrial processes. With a worldwide reputation for reliability, innovation and technological excellence, the Company produces equipment for concentration and mass monitoring for regulatory, environmental and process control requirements. A dedicated team of qualified application and sales engineers is always on hand and should be consulted in the selection and usage of the most suitable equipment for any particulate application.



PCME Ltd

Clearview Building, 60 Edison Road
St. Ives, Cambs PE27 3GH UK

Tel: Int +44 (0)1480 468200
Fax: Int +44 (0)1480 463400
E-mail: sales@pcme.co.uk

Contact your national or area sales and service office