

# Innovation in Gas Analysis

## JCP Portable Gas Conditioning Systems



### APPLICATION

- For mobile or stationary extractive gas analysis
- For emission and process monitoring
- Continuous sample gas conditioning of humid process gases
- Continuous drying of sample gas to a precise low and constant outlet dew point
- Minimises water vapour cross sensitivities and volumetric errors

### BENEFITS

- Complete solution for a great number of applications
- Longterm reliable reproducible measuring results
- Optimum operational safety due to self-monitoring
- Extremely precise long term stable dew point even under varying loads
- Fast response time due to low dead volume
- Continuous condensate removal
- Low maintenance operation
- Easy to maintain design

### FEATURES

- Light weight robust aluminium housing
- Low total weight of 6,5 to 13 kg depending on model and equipment
- Basic device with Peltier sample gas cooler and condensate pump
- Many equipment options with the following components:
  - Digital temperature indication
  - High performance corrosion resistant sample gas pump
  - Easy to maintain robust fine dust filter
  - Corrosion resistant flowmeter with precise needle valve
  - Reliable condensate monitoring
  - Temperature controller for heated sample line
  - Solenoid valve for calibration gas feeding
  - Wall mounting rails
  - 19"-rack mounting set



# JCT

Analysentechnik  
GmbH

Gas Sampling Probes

Heated Sample Lines

Sample Gas Coolers

Condensate  
Treatment

Accessories

Gas Conditioning  
Systems

Sample Gas  
Converters

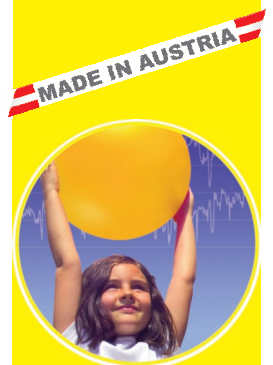

[www.jct.at](http://www.jct.at)

## TECHNICAL DATA

Model	JCP-E / JCP-FE / JCP-FPE	JCP-S	JCP-SL
Description	portable sample gas conditioning system		
Installation	free standing (wall mounting or 19"-rack mounting as option)		
Cooling principle	Peltier		
Number of heat exchanger / gas paths	1 / 1		
<b>Operation</b>			
Flow rate*	max. 240 NI/h		
Gas temperature inlet*	max. +150°C		
Dew point inlet*	max. +70°C		
Dew point outlet	+4°C		
Dew point stability (for constant inlet conditions)	±0,2K		
Ambient temperature	+5...+40°C		
Operating pressure	0,2...2,2 bara		
Ready for operation	< 15 min.		
Pressure drop at max. flow rate	5 mbar		
<b>Construction</b>			
Dimensions over all ( W x H x D )	330 x 266 x 220 mm	448 x 266 x 220 mm	
Operating position	horizontal		
Weight	ca. 6,5...8,5 kg	ca. 13 kg	
Housing, colour	aluminium, natural anodised		
Material heat exchanger	PVDF		
Dead volume per gas path	50 ml		
Connection sample gas inlet	PVDF hose fitting DN 4/6 mm optional: stainless steel fitting 6 mm	stainless steel fitting 6 mm	
Connection sample gas outlet	PVDF hose fitting DN 4/6 mm		
Connection condensate outlet	PVDF hose fitting DN 4/6 mm		
Connection calibration gas inlet (option)	PVDF hose fitting DN 4/6 mm		
Approvals / signs	CE		
<b>Electrics</b>			
Power supply	230 VAC 50/60 Hz or 115 VAC 50/60 Hz ±10 %		
Power consumption (depending on load, ambient temperature and configu- ration)	30...160 VA	30...160 VA (+ max. 1800 W heated sample line)	
Power connection / connection cable	IEC device socket / CEE 7/7 plug to IEC plug, 2 m cable		
Fusing	lead fuse T2A (built in IEC plug)		
Protection class	IP 20 (EN 60529)		
On - time	100 %		
Alarm set points	<0 / >+10°C		
Connection heated sample line	7-pole socket „Binder“ series 693		
Max. load heated sample line			230 VAC 8 A max. 1800 W
Temperature sensor heated sample line (setting ex works , others on request)			thermocouple „K“ (Ni/CrNi)

\* Results from the effective cooling capacity at 25°C ambient temperature and 3°C outlet dew point and can be influenced by further operational parameters

## DIMENSIONS

### JCP-E / JCP-FE / JCP-FPE

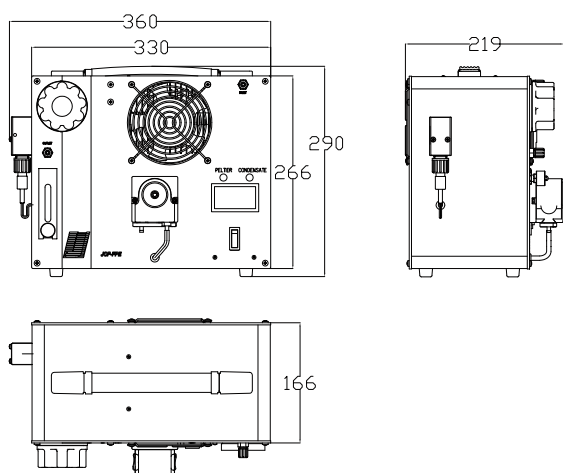

### JCP-S / JCP-SL

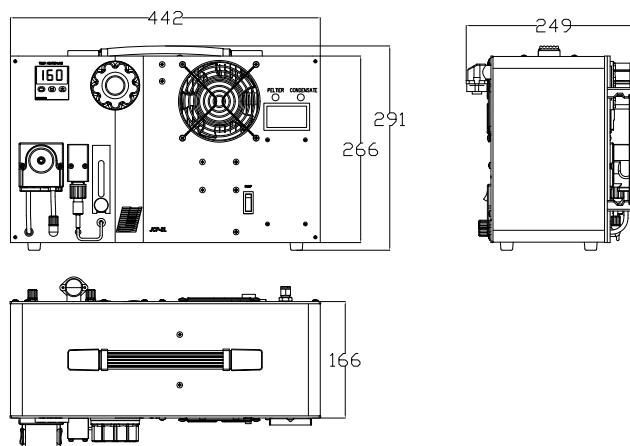

Dimensions in mm

## GAS FLOW DIAGRAMS

### JCP-E

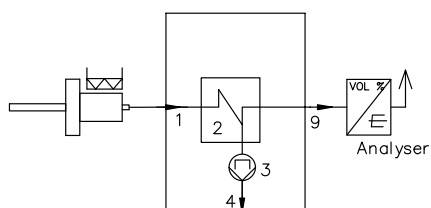

### JCP-FE

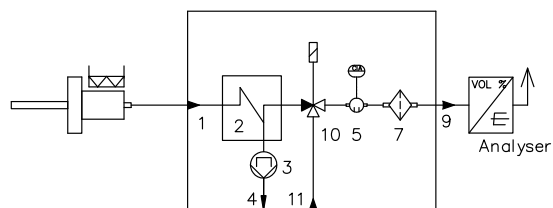

### JCP-FPE / JCP-S

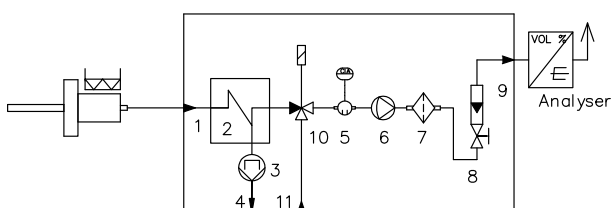

### JCP-SL

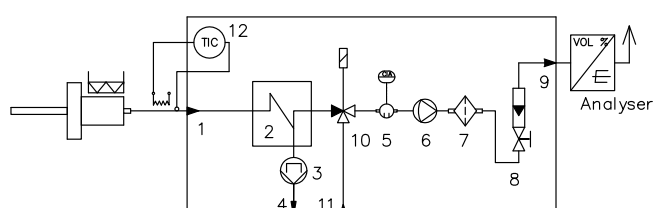

- |   |  |
|---|--|
| 1 | Sample gas inlet   |
| 2 | Gas heat exchanger   |
| 3 | Condensate pump JSR-25                                       |
| 4 | Condensate outlet  |
| 5 | Condensate sensor KW-1<br>(for JCP-FE and JCP-FPE as option) |
| 6 | Sample gas pump  |

- |    |  |
|----|--|
| 7  | Sample gas filter                                  |
| 8  | Flow meter with needle valve                       |
| 9  | Sample gas outlet                                  |
| 10 | Solenoid valve (option)                            |
| 11 | Calibration gas inlet (option)                     |
| 12 | Temperature controller heated sample line (option) |

## ORDER CODES

### JCP-...

Model	JCP-E	JCP-E	JCP-FE	JCP-FE	JCP-FPE	JCP-FPE	JCP-S	JCP-S	JCP-SL	JCP-SL
Order code	12.10000	12.10001	12.11050	12.11051	12.12100	12.12101	12.15000	12.15001	12.15100	12.15101
Filter JF-1			X	X	X	X	X	X	X	X
Sample gas pump					X	X	X	X	X	X
Temperature display					X	X	X	X	X	X
Flowmeter with needle valve					X	X	X	X	X	X
Condensate detector							X	X	X	X
Large housing							X	X	X	X
Temperature controller sample line									X	X
Sample gas inlet stainless steel SS316							X	X	X	X
230 VAC 50/60 Hz	X		X		X		X		X	
115 VAC 50/60 Hz		X		X		X		X		X

### Additional options

12.00003 C sample gas inlet SS316	X	X	X	X	X	X				
12.00065 KE condensate detector			X	X	X	X				
12.00021 V solenoid valve 230 VAC*			X		X		X		X	
12.00021S V/S solenoid valve 115 VAC*				X		X		X		X
12.15120 WA wall mounting set			X	X	X	X	X	X	X	X
12.15110 19" rack mounting set							X	X	X	X

\* Only in combination with condensate detector

### JCP-FPE



## JCT Analystechnik GmbH

Werner Heisenberg-Straße 4 A-2700 Wiener Neustadt  
 Tel. +43 (0) 2622 / 87201 Fax +43 (0) 2622 / 872011  
 E-Mail: [sales@jct.at](mailto:sales@jct.at) Web: [www.jct.at](http://www.jct.at)

