

# Particulate Measurement System

PROCESS & EMISSIONS MONITORING SYSTEMS



**ELECTRODYNAMIC**  
INSIDE

## SPECIFIC FEATURES:

- Reliable measurement of particulate emissions ( $\text{mg}/\text{m}^3$ ) using unique *ElectroDynamic*® Probe Electrification technology
- Multilingual display
- PRO version permits multichannel networked system for plant-wide monitoring of emissions (for up to 32 sensors)
- Inbuilt data recording for either leak-location diagnostics or instrument calibration (default setting)
- Inbuilt automatic probe rod self-checks for ongoing quality assurance

# TECHNOLOGY

## SYSTEM DESCRIPTION AND PRODUCT RANGE

The PCME VIEW 370 series is designed for emission measurement with high quality where calibration for mg/m<sup>3</sup> via an isokinetic sample can be correlated with data stored in the in-built short-term (ST) logger. Unlike other dust monitors, the instrument is internally calibrated with all data, outputs and results calibrated and scaled directly in mg/m<sup>3</sup>. The PCME VIEW 370 'Broken bag mode' facilitates the detection of leaking filter bags from bagfilters before broken bags are present. This advanced diagnostic mode enables better operation of bagfilters and lower running costs from reducing replacement bags.

Detection of bag leaks or broken-bag location can be either "on-screen" or on a PC (via the optional PC software tool). Predictive bag leakages and locations of leaking bag rows can be identified in single-chamber, multi-row bagfilters, whereas for multi-chamber bagfilters, the system can be extended to monitor each chamber. Please consult ENVEA or your local ENVEA representative for bag-filter performance datasheet details.

Please note that only one of the following three functions can be active at any given time:

1. Bag leak/broken bag mode – Pulse logger enabled.
2. Process control mode – Short-term (ST) logger enabled.
3. Emissions reporting – Long-term (LT) logger enabled (PCME VIEW 373 sensors only).

The alarm log is always enabled. The operator can quickly switch between modes and switch back again when required.

### Bag Leak and Broken Bag Mode (1)

- Dust pulse each cleaned bag row is displayed in real-time and stored for analysis in the instrument pulse log (single-chamber bagfilters).
- Real-time or historical data analysis of bag-cleaning cycles can be reviewed and compared for determining:
  - ♦ Deterioration of filter media between cleaning cycles.
  - ♦ Faulty pulse valve operation.
  - ♦ Incorrectly fitted bags (after replacement).

### Process Control (2)

Using the instrument's ST logger, the operator can:

- Review short-term process trends to determine process upsets.
- Review emission excursion events and compare to process conditions for comparison.
- Use the data stored for direct comparison to isokinetic sample for instrument calibration.

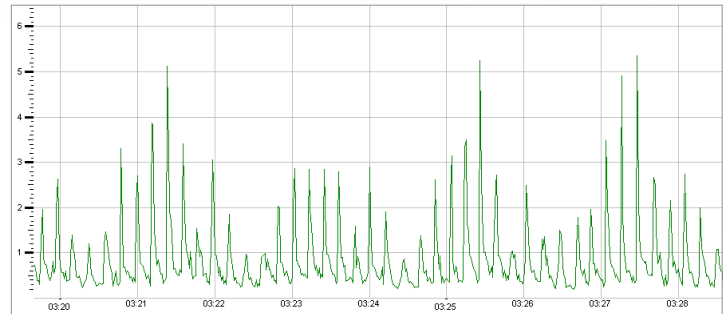

Bagfilter cleaning pulses are clearly visible when using the inbuilt pulse logger with PC-ME DUST TOOLS software

### Alarm Data

The inbuilt alarm log stores all defined alarm events. This data can be viewed "on-screen" or downloaded to a PC and enables storage and reporting of:

- Emission alarms (both instant and average)
- Bag-leak detection warning alarms.
- Instrument self-check failure alarms (zero, span, power interrupt, comms to sensor).

### Emissions Reporting (3)

PCME VIEW 373 only – the inclusion of a LT built-in data logger allows for:

- Reporting of emission averages for environmental compliance (software).
- Long-term process trend analysis for process optimisation (optional, soft-ware required) and reduction of dust emissions.

## PRINCIPLES OF OPERATION

The instruments use ENVEA's unique and patented *ElectroDynamic*<sup>®</sup> Probe Electrification technology. The sensor electronics measure the current signature created by particles interacting with the grounded sensing rod which protrudes into the stack. The electronics extract a specific frequency band of this signal and electronically filter out the DC current caused by particle collisions. This signal may be correlated to dust concentration by comparison to the results of an isokinetic sample for those types of industrial stack applications for which the instrument is designed (see Application Conditions).

**Core features of the *ElectroDynamic*<sup>®</sup> Probe Electrification technology** are that the signal generated is:

- Unaffected by contamination on the sensor rod (which may cause signal drift issues for other systems).
- Not affected by velocity variations within typical bagfilter velocity ranges (see separate TUV approvals for ENVEA technology).
- Reliable and stable in the target applications for the instrument (see Process Conditions above). Identical ENVEA technology to this is used in the PCME QAL 991 instrument, which was the first ever probe electrification instrument to become TUV and MCERTS approved against the exacting standard of EN15267-3 for QAL1.

### Technology Comparisons and Benefits

Compared to DC triboelectric systems and 'induction sensing and protected probe systems' *ElectroDynamic*<sup>®</sup> systems have the following added benefits:

- Tolerance to contamination on the rod.
- Stable results and calibrations (protected probes are not necessary in dry applications and, therefore, drift caused by electrostatic charging effects is avoided).
- Reduced sensitivity to the effects of changing velocity.

**ELECTRODYNAMIC**<sup>®</sup>  
INSTRUMENTS

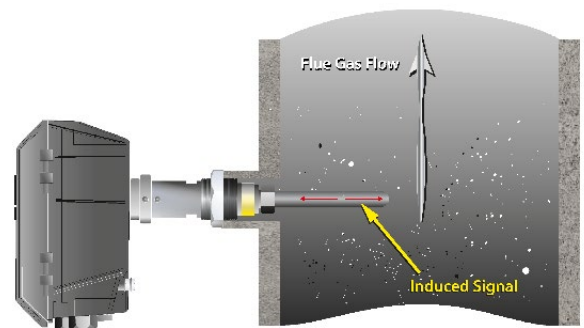

Compared to other types of AC systems, *ElectroDynamic*<sup>®</sup> systems have the following added benefit:

- An optimised frequency spectrum to extend the velocity range over which the system has no cross-sensitivity to changing velocity (see TUV approvals).

# PRODUCT FEATURES

## PROCESS AND APPLICATION CONDITIONS

- Measurement capability from 0–10 mg/m<sup>3</sup> to 0–500 mg/m<sup>3</sup> (automatic range changes).
- Long-term zero drift: <0.1 mg/m<sup>3</sup>
- Recommended maintenance inspection frequency: every 6 months
- For stack measurement, but not suitable for electrostatic precipitators (ESPs) or applications with water droplets.
- Stack diameter: Ø100 mm to 6 m
- For use in bagfilter applications with a flow of 8–20 m/s, no restrictions.

## FEATURES AND NETWORK LAYOUT

- Expandable up to 32 dust sensors digitally linked to central control unit (PRO version).
- Quality Assurance features and screens for analysis of self-checks results.
- Alarms (with configurable delay) based on both rolling average data and instantaneous data for reliable plant failure detection and diagnostics.
- Unique graphics display and data logger (for trend analysis).
- Automatic zero, span, probe contamination and communication checks.
- Secure data and password protection.
- Auto-ranging feature (instrument adjusts its dynamic range to track fast-moving dust pulses typically found after reverse-jet baghouses) to ensure good measurement.
- Simple calibration mode after isokinetic sample.
- Accepts inputs from analysers for on-board normalisation (T, oxygen, P).\*
- Interlinks to PC-ME DUST TOOLS reporting and analysis software for on-line control and historical reporting using a PC or laptop.
- PRO version available for expansion of the system (up to 32 sensors).

\*Requires an Auxiliary Input Module (AIM).



## SENSOR DIMENSIONS AND OPTIONS

### Standard Sensor 0–250°C/0–800°C

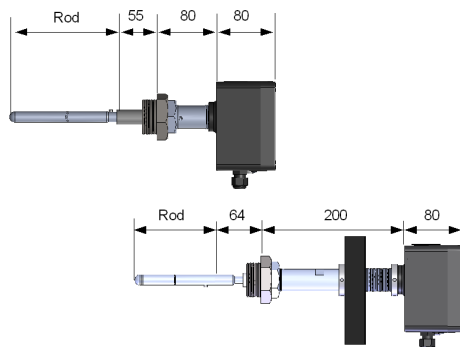

### Insulated Sensor 0–250°C

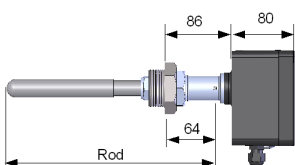

### Passive/Active Sensor 0–250°C

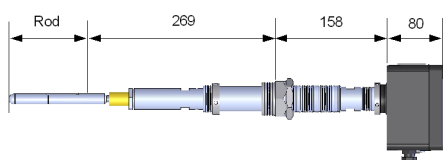

### PCME VIEW 370 / PCME VIEW 373 Sensor Specifications

Sensor Variants	Standard sensor	0–250°C, option: up to 400°C/800°C
	Insulated sensor	0–250°C*
	Passive/active sensor	0–250°C
Ambient Temperature Range	-20°C to 50°C	
Enclosure Dimensions	W 122 x H 122 (146) x D 80 mm (incl. cable glands)	
Protection Rating	IP65	
Enclosure Material	Die-cast aluminium (epoxy coated)	
Cable Entries	2x M16 cable glands	
Weight	1.8 kg (standard sensor)	
Sensor Probe Material	316 Stainless steel, insulated: PTFE-coated stainless steel	
Stack Connection	1½ in. BSP (female) <b>Note: ensure the opening/port hole in stack wall is at least Ø45 mm.</b>	
Power Supply Voltage	24V DC (via the control unit)	
Local Output	RS-485 connection (to control unit)	
Air Purge Requirements	May be required on some applications. Requires air purge fitting and external supply of 5–10 litres/minute of dry, clean instrument air.	
Cable type	4-core, screened (10 m supplied as standard)	
Hazardous Zone Classification	ATEX / IECEx Dust zones 20/21 (Cat.1D) and 22 (Cat.3D)	

\*Non-Ex versions only.

## TECHNICAL SPECIFICATIONS- CONTROL UNITS AND NET MODULES

Network Controllers		Standard Controller	ProController
Overview	Number of sensors/channels	1	1-32
	Display	Two-tone grey, backlit graphical LCD	High-contrast, anti-glare 7" (viewable) TFT LCD
	Multiple Data Viewing	PC or RS-485	PC/RS-485/Ethernet simultaneously
	Dimensions	W220 x H124 x D80 mm	W390 x H221 x D118 mm
	Power supply voltage	100-240V AC (50/60 Hz)	85-265V AC (50/60 Hz)
	Protection Rating	IP65	IP66
	Ambient Temperature Range	-20°C to 50°C	-20°C to 50°C
Features and Functions	Navigation keys	UP/DOWN/LEFT/RIGHT/ENTER	UP/DOWN/LEFT/RIGHT/ENTER plus 5 function keys: 3x short-cut keys and 2 user-programmable keys
	Icon-driven, multilingual menus	n/a	✓
	Secure password protection	✓	✓
	Sensor system setup and configuration options	✓	✓
	Configurable emission alarm levels	✓	✓
	Sensor calibration screens	✓	✓
Data Logging*	Seamless integration with existing control units and sensors	n/a	✓
	Long-term Log**	12 months @ 15 minutes	48 months @ 15 minutes
	Short-term Log	7 days @ 1 minute	28 days @ 1 minute
	Pulse Log	8 hours @ 1 seconds	32 hours @ 1 second
System Outputs	Alarm Log	500 entries	500 entries
	Ethernet (RJ45)	n/a	✓ Connection type: 100Base-T/Tx 100 Mb/s
	USB 2.0	n/a	✓ Suitable for connecting to a local PC or laptop
	Relays	2 off (programmable)	4 off (programmable)
	4-20mA	1 off (programmable)	4 off (programmable)
System Inputs	RS-485	1	1
	Digital User selectable for: PLANT OFF indication, Bag-filter cleaning sequences, multiple calibrations	1	4
	4-20mA	0	2

\*Data logging capacity for one sensor. Data stored varies per sensor type. Please consult ENVEA for specific data. \*\*PCME VIEW 373 sensors only.

Network Modules <i>(can be connected to Controller Network systems to provide additional Inputs and Outputs)</i>	<b>Analogue Output Module (AOM)</b> provides 8 additional 4-20 mA outputs definable to sensors/channels	1	1-8
	<b>Auxiliary Input Module (AIM)</b> provides 4 additional digital inputs, plus 4 additional relay outputs	1	1-8
	<b>Relay Output Module (ROM)</b> provides 8 additional relay outputs	1	1-8
	<b>SPUR</b> provides sensor network connection and local isolation during maintenance	1	1-32
	<b>Power Supply Repeater (PSR)</b> provides voltage and signal boost for extended cable runs and large sensor networks	1	1-8

## ABOUT ENVEA

As a progressive environmental Company, ENVEA specialises in particulate measurement for industrial processes. With a worldwide reputation for reliability, innovation and technological excellence, the Company produces under the trademark envea™ equipment for concentration and mass monitoring for regulatory, environmental and process control requirements. A dedicated team of qualified application and sales engineers is always on hand and should be consulted in the selection and usage of the most suitable equipment for any particulate application.



ENVEA UK  
ENVEA House Rose and Crown Road  
Swavesey / Cambridge - UK CB24 4RB  
☎ +44 (0)1480 468200  
✉ contact.gb@envea.global



www.envea.global