

## Light Scatter Particulate Emission Monitor

PROCESS & EMISSIONS MONITORING SYSTEMS

Part of ENVEA's family of Backscatter particulate measurement sensors, the DM 170 is designed to comply with the TUV suitability testing scheme to EN 15267 and for measuring dust concentrations in a wide range of industrial applications.

Due to its wide dynamic range, the DM 170 may be used in Combustion applications as well as in higher dust loading applications (such as Power, Cement and Metals smelting, and in processes without filtration). Its simplicity and wide operating range makes it also ideally suited for process optimisation applications.



DM 170 shown with Manual Audit Unit



Telescope Field-of-View

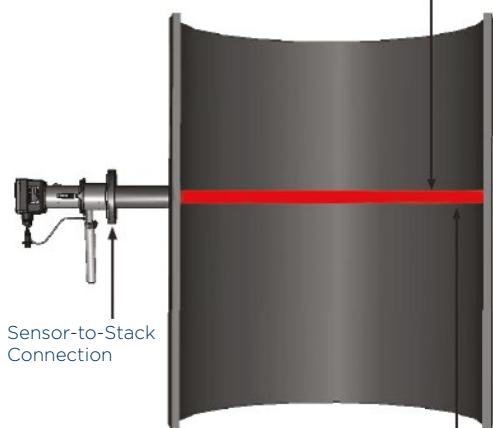

Sensor-to-Stack Connection

Outgoing Laser Beam

### KEY FEATURES:

- **ProScatter®** Backscatter sensor technology with superior minimum detection level as low as  $1 \text{ mg/m}^3$  compared to conventional techniques
- Manual and remote Zero and Span (Reference) checks available to ensure optimal instrument performance
- Purge Flow Fail Sensor and Optical Shield options
- Non-intrusive system designed to operate in non-condensing stack environments and to reduce the risk of contamination
- Contamination risks are further reduced due to single-side stack installation where critical optical components remain outside the stack
- A Flue Gas Blocker can be fitted to ensure that flue gases do not escape when the unit is opened (for auditing/maintenance purposes), thus enhancing on-site personnel safety
- Offers a more reliable PM dust measurement as an alternative to Opacity and Scintillation based monitors for emissions that are reported in  $\text{mg/m}^3$  and provides early indication of increased dust emissions in processes with low dust concentrations

### INDUSTRIES AND APPLICATIONS:

The DM 170 is well-suited for use in medium to large stacks and is suitable for low to high dust concentration measurements, regardless of dust velocity or charge. Typical applications include:

- Continuous Emission Monitoring (CEM) relative to Emission Limit Values (ELV) in Power Plant, Boiler and Metal Smelting applications
- Filter performance monitoring in Metal, Mineral and Chemical plants



THE QUEEN'S AWARDS  
FOR ENTERPRISE  
2017

# PRODUCT SPECIFICATIONS

PCME DM 170

## EMISSIONS & PROCESS MONITORING SYSTEMS

### PRINCIPLE OF OPERATION:

The DM 170 is based on ENVEA's class-leading ProScatter® Backscatter technology.

Particles in the stack are illuminated by a laser and the amount of laser-light scattered back from the particles is measured by a detector. Stray scattering and ambient light are eliminated by tuning the instrument's field-of-view and by use of a modulated laser source.

The instrument response is proportional to dust concentration. It can be calibrated to provide a mg/m<sup>3</sup> measurement by comparison to results of a standard reference (isokinetic) test.

With the ability to measure dust levels as low as 1 mg/m<sup>3</sup>, the DM 170 can be used in applications where emissions are well below the sensitivity limit of traditional Opacity instruments.

PROCESS/APPLICATION CONDITIONS	
Application Suitability	Suitable for measurement in non-condensing flue gases
Location Suitability	Outdoor or sheltered use; safe for ambient temperature of -20 to 50°C (-4 to 122°F)
Flue Gas Temperature (at monitoring point)	-20°C to 250°C (-4°F to 482°F) option: up to 400°C (752°F)
Stack Pressure	320 mbarG
Stack Diameter*	1.5 - 15 m (5 - 50 ft)
Flue Gas Composition	Non-condensing
Hazardous Zone Classification	ATEX Zone 2/22
Stack Connection	3" 150 lb ANSI flange DN80 PN10/PN16 flange JIS 100-5k, -10k flange

AIR PURGE REQUIREMENTS	
Requires an external supply of 1000 l/min of dry, clean (oil-free) air.	
Type	Medium Purge Blower
Power supply voltages (options)	110V AC, 50/60Hz, 7A 230V AC, 50/60Hz, 2.3A
Blower tubing	3 m (10 ft) hose with fittings (supplied)
Air Filter	Standard (included)
Noise pressure level	<80 dBA
Cable entries	1x M20 cable gland

MEASUREMENT INFORMATION	
Measurement Type	Light Scattering
Resolution	0.1 mg
Response Time	2 seconds
Dust Levels	<1 to 1000 mg/m <sup>3</sup>

\*application specific, please consult ENVEA

SENSOR OPTIONS	
Sensor Versions	Standard Sensor: up to 250°C (482°F) High-temperature sensor: up to 400°C (752°F)*
Sensor Material	316 Stainless Steel
Sensor Dimensions	L 354 x H 216 x B 204 mm (14 x 8.5 x 8 in.), including flange and cable glands
Zero/Span Sensor Checks	Included
Protection Rating	IP65
Power Supply Voltage	100 - 240V AC 50/60, 1A 24V DC
I/O	Outputs : 1x 4-20mA 2x Alarm relays 1x RS-485 output Inputs : 1x Digital input
Manual Audit Capability	Single, compact unit (available in a selected range of dust concentrations)
Automatic Air Purge Failure Check	Option

\*with Purge Air Flow sensor (standard on high-temperature sensors)

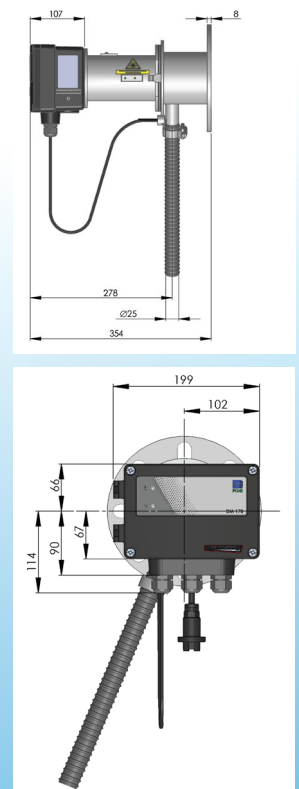

## ABOUT ENVEA

As a progressive environmental Company, ENVEA specialises in particulate measurement for industrial processes. With a worldwide reputation for reliability, innovation and technological excellence, the Company produces under the trademark envea™ equipment for concentration and mass monitoring for regulatory, environmental and process control requirements. A dedicated team of qualified application and sales engineers is always on hand and should be consulted in the selection and usage of the most suitable equipment for any particulate application.



ENVEA UK  
ENVEA House Rose and Crown Road  
Swavesey / Cambridge - UK CB24 4RB  
☎ +44 (0)1480 468200  
✉ contact.gb@envea.global



www.envea.global