

1991

QAL1

CEM

PCME

ProController

EN 15267-3

EN 14181

EN 13284-2



# QAL1 Approved PM-CEM

PROCESS & EMISSIONS MONITORING SYSTEMS

**ELECTRODYNAMIC™**  
INSIDE



## SPECIFIC FEATURES:

- Complies with standards EN 13284-2, EN 14181 and EN 15267-3
- Suitable for bag-filter applications with an Emission Limit Value (ELV) of 7.5 mg/m<sup>3</sup> (Incineration) and 15 mg/m<sup>3</sup> (Co-incineration)
- Automatic recording of span and zero checks to satisfy QAL3 requirements

## COMPLIANCE WITH:

EN 13284-2, EN 14181 and EN 15267-3



# TECHNOLOGY / APPLICATION

## SYSTEM DESCRIPTION

The PCME QAL 991 is an approved particulate CEM (Continuous Emission Monitor) complying with monitoring standards EN14181 and EN13284-2. The instrument holds a QAL1 approval to the latest performance requirements specified in EN15267-3.

The PCME QAL 991 benefits from using patented *ElectroDynamic*<sup>®</sup> measurement technology and is particularly suited for monitoring emissions from Waste Incineration Plant where emissions are controlled with dry scrubbing and bag-filter technology.

The instrument may also be used in other industrial processes controlled with high-efficiency bag filtration. The sensor is provided with a passive/active design to eliminate any concerns or effects of condensation in the stack connection stub.



©Dorthern Filtration Ltd. Reproduced with kind permission.

## APPLICATION AND CERTIFICATION CONDITIONS

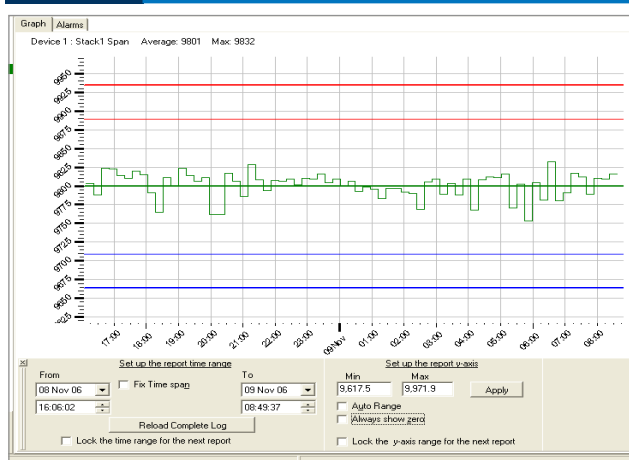

Upper limit  
Upper limit warning

Lower limit warning  
Lower limit

- Certification range: 0–7.5 mg/m<sup>3</sup> (stated in the QAL1 approval)
- Long-term zero drift: <0.1 mg/m<sup>3</sup>
- Inspection frequency: every 6 months
- For measurement in non-condensing flue gases.
- Suitable for use in process applications controlled by bag filters. Not suitable after Electrostatic Precipitators (ESPs) or in applications with water droplets.
- No Velocity restrictions in processes of between 8 and 20 m/s.
- For Stack diameters >500 mm.

QAL Reporter – Shewart Chart of span for QAL3

## TYPICAL USE AND APPLICATIONS

The instrument uses ENVEA's unique and patented *ElectroDynamic*<sup>®</sup> Probe Electrification technology. The sensor measures the current signature created by particles interacting with the sensing rod which protrudes into the stack.

The sensor extracts a specific frequency band of this signal and electronically filters out the DC current caused by particle collisions. This signal may be correlated to dust concentration by comparison to the results of an isokinetic sample (the Standard Reference Method for particulate) for those types of industrial applications for which the instrument is designed.

Core features of the *ElectroDynamic*<sup>®</sup> Probe Electrification technology are that the signal generated is:

- Unaffected by contamination on the sensor rod (which may cause signal drift issues for other systems).
- Not affected by velocity variations within typical bag-filter velocity ranges.

### Technology Comparisons and Benefits

Compared to DC triboelectric systems and 'induction sensing and protected probe systems', *ElectroDynamic*<sup>®</sup> systems have the following added benefits:

- Tolerance to contamination on the rod.
- Stable results and calibrations (insulated probes are not necessary in dry applications and, therefore, drift caused by electrostatic charging effects is avoided).
- Reduced sensitivity to the effects of changing velocity.



Compared to other types of AC systems, *ElectroDynamic*<sup>®</sup> systems have the following added benefit:

- An optimised frequency spectrum to extend the velocity range over which the system has no cross-sensitivity to changing velocity (as per TUV approvals).

### Added Value Features

The PCME QAL 991 includes an advanced level of automatic functionality checks to provide high-quality assurance as well as being fully QAL1 compliant:

- A unique, patented probe rod Short-circuit check – to enable the instrument to detect (and hence avoid) the sensing rod becoming electrically shorted to the stack which would cause errors.
- Automatic Zero and Span checks – as required for QAL3 reporting according to EN 14181.

The system also includes advanced signal processing and diagnostics to permit operators to locate leaking bags in large bag-filter applications:

- Rapid dynamic ranging of 10,000:1 permitting bag-cleaning pulses to be accurately monitored while maintaining high accuracy in background emission measurement. Sufficient dynamic range is provided to follow 'on-line' and 'off-line' bag-cleaning cycles for predictive filter failure and faulty bag location detection.

# PRODUCT FEATURES

## USER-SELECTABLE ADDED VALUE OPTIONS

The PCME QAL 991 sensor provides a complete solution for measurements according to EN14181 in its specified application range.

The instrument holds a QAL1 certification range of 0–7.5 mg/m<sup>3</sup>, meaning that it is suitable for compliance reporting from processes with daily Emission Limit Values (ELVs) as low as 5 mg/m<sup>3</sup> (e.g. Incineration plant).

The measurement and calibration features facilitate a 15-point/5-point calibration (QAL2) and permit the specification of a valid calibration range. The internal Quality Assurance features of the instrument have been designed and approved to meet the QAL3 and AST requirements of EN14181.

- Automatic zero, span and contamination self-checks are used to assess internal uncertainty. The results of these tests are recorded for later statistical analysis.

This provides the infrastructure for QAL3 reporting according to EN14181.

- The optional QAL Reporter PC software module provides secure emissions and QAL3 reporting. It enables statistical treatment of the Zero and Span results for users to demonstrate that the instrument is operating according to defined specifications (uncertainty).
- The instrument is supported by an optional *ElectroDynamic*<sup>®</sup> Audit unit, which is an approved reference method for conducting linearity tests as part of AST or QAL2 procedures. When using this accessory, the sensor is inserted in the audit chamber. Signal levels are applied to the sensor as references and these are measured to ensure linearity and performance against specifications.

## SYSTEM LAYOUT

Two versions of the PCME QAL 991 system are available: the Standard version for single sensors and the PRO version for multi-sensor networked systems powered by the ProController, which provides central communications for analysing emissions data and trends and compliance reporting, as well as data recording for multiple sensors (up to 32 sensor channels) for multi-stack and plant-wide systems and links the sensors into data acquisition systems (DAHS/DCS).

A number of interfaces (including fast Ethernet, RS-232/RS-485 over Modbus and USB 2.0) are available for simultaneous communications to data reporting systems and for temporary service connections. The PC-ME DUST TOOLS software suite provides further functionality.

Ex versions of the instrument are rated for ATEX Gas zone 2 and Dust zone 22, as well as for IECEx Gas zone 2 and Dust zones 20/21 and 22.

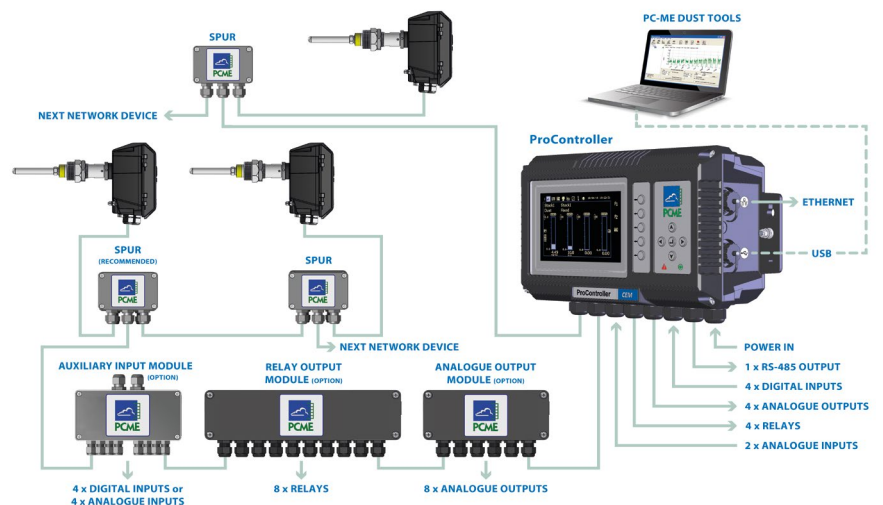

Typical multi-sensor system

## SENSOR SPECIFICATIONS

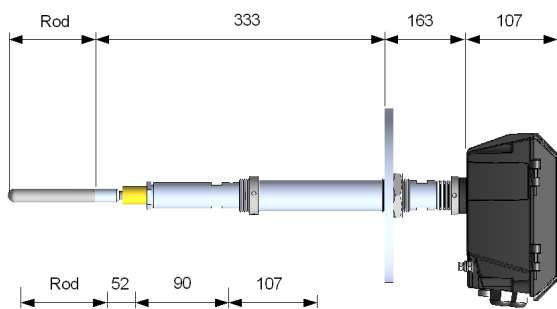

Standard passive/active Sensor 0–250°C

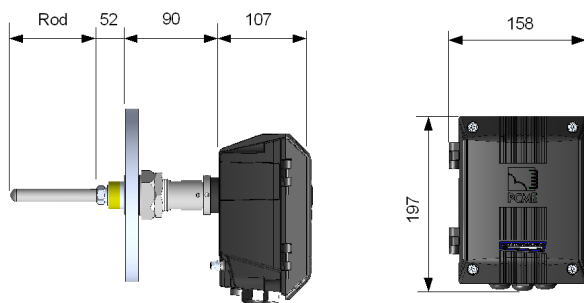

Non-Passive Sensor 0–250°C

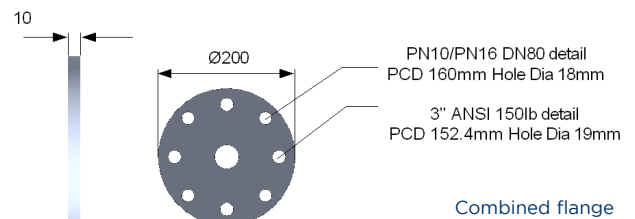

Combined flange

PCME QAL 991 – SENSOR SPECIFICATION AND OPTIONS*	
Ambient Temperature	-20°C to 50°C
Enclosure Protection Rating	IP65
Enclosure Material	Die-cast aluminium (polyester powder coated)
Sensor Rod	316 Stainless steel, PEEK/Sialon (insulator)
Stack Connection	DN80 PN10/PN16 // 3" 150lb ANSI flange 1½ in. BSP (option)
Power Supply Voltage	18–24V DC (from the control unit)
Cable Entries	3x M20 cable glands
Air Purge Requirements (option)	Air purge fitting and external supply of 5–10 L/min of dry, clean (oil-free) instrument air.
Hazardous Zone Classification	ATEX Gas zone 2 (500°C), Dust zone 22 (250°C) ATEX Gas/Dust zones 2 and 22 (up to 500°C) IECEx Dust zone 2 or 20/21/22 (up to 400°C)

\*Local 4-20mA and Relay outputs are available for all sensor types (excl. Ex variants). Refer to the PCME QAL 991 Order Codes Guide (available on request).

# SPECIFICATIONS

## TECHNICAL SPECIFICATIONS - CONTROL UNITS AND NET MODULES

NETWORK CONTROLLERS		STANDARD CONTROLLER	PROCONTROLLER
OVERVIEW	Number of sensors/channels	1	1-32
	Display	Two-tone grey, backlit graphical LCD	High-contrast, anti-glare 7" (viewable) TFT LCD
	Multiple Data Viewing	PC or RS-485	PC/RS-485/Ethernet simultaneously
	Dimensions	W220 x H124 x D80 mm	W390 x H221 x D118 mm
	Power supply voltage	100-240V AC (50/60 Hz)	85-265V AC (50/60 Hz)
	Protection Rating	IP65	IP66
	Ambient Temperature Range	-20°C to 50°C	-20°C to 50°C
FEATURES AND FUNCTIONS	Navigation keys	UP/DOWN/LEFT/RIGHT/ENTER	UP/DOWN/LEFT/RIGHT/ENTER plus 5 function keys: 3x short-cut keys and 2 user-programmable keys
	Icon-driven, multilingual menus	n/a	✓
	Secure password protection	✓	✓
	Sensor system setup and configuration options	✓	✓
	Configurable emission alarm levels	✓	✓
	Sensor calibration screens	✓	✓
	Seamless integration with existing control units and sensors	n/a	✓
DATA LOGGING*	Long-term Log	12 months @ 15 minutes	48 months @ 15 minutes
	Short-term Log	7 days @ 1 minute	28 days @ 1 minute
	Pulse Log	8 hours @ 1 seconds	32 hours @ 1 second
	Alarm Log	500 entries	500 entries
SYSTEM OUTPUTS	Ethernet (RJ45)	n/a	✓ Connection type: 100Base-T/Tx 100 Mb/s
	USB 2.0	n/a	✓ Suitable for connecting to a local PC or laptop
	Relays	2 off (programmable)	4 off (programmable)
	4-20mA	1 off (programmable)	4 off (programmable)
	RS-485	1	1
SYSTEM INPUTS	Digital User selectable for: PLANT OFF indication, Bag-filter cleaning sequences, multiple calibrations	1	4
	4-20mA	0	2

\*Data logging capacity for one sensor. Data stored varies per sensor type. Please consult ENVEA for specific data.

Network Modules (can be connected to Controller Network systems to provide additional Inputs and Outputs)	NETWORK ACCESSORIES	STANDARD CONTROLLER	PROCONTROLLER
	<b>Analogue Output Module (AOM)</b> provides 8 additional 4-20 mA outputs definable to sensors/channels	1	1-8
<b>Auxiliary Input Module (AIM)</b> provides 4 additional digital inputs, plus 4 additional relay outputs	1	1-8	
<b>Relay Output Module (ROM)</b> provides 8 additional relay outputs	1	1-8	
<b>SPUR</b> provides sensor network connection and local isolation during maintenance	1	1-32	
<b>Power Supply Repeater (PSR)</b> provides voltage and signal boost for extended cable runs and large sensor networks	1	1-8	

## ABOUT ENVEA

As a progressive environmental Company, ENVEA specialises in particulate measurement for industrial processes. With a worldwide reputation for reliability, innovation and technological excellence, the Company produces under the trademark envea™ equipment for concentration and mass monitoring for regulatory, environmental and process control requirements. A dedicated team of qualified application and sales engineers is always on hand and should be consulted in the selection and usage of the most suitable equipment for any particulate application.



ENVEA UK  
ENVEA House Rose and Crown Road  
Swavesey / Cambridge - UK CB24 4RB  
☎ +44 (0)1480 468200  
✉ contact.gb@envea.global



www.envea.global