

STACKFLOW 200



Flue Gas Velocity Measurement System

PROCESS & EMISSIONS MONITORING SYSTEMS



SPECIFIC FEATURES:

- Continuous high-quality measurement of flue gas velocity, temperature and pressure
- Volumetric flow rate, pollutant mass release and normalisation to standard reference conditions
- Modular system flexibility with upgrade solutions for challenging application conditions
- Manual reference self-checks for quality assurance and regulatory compliance (QAL3)



THE QUEEN'S AWARDS
FOR ENTERPRISE
INNOVATION
2017

Certified to EN 15267-3
with QAL1 as defined by EN 14181
Approved using EN 16911-2
US EPA PS-6 capable

TECHNOLOGY / APPLICATION

PRODUCT OVERVIEW

The PCME STACKFLOW 200 is an advanced flue gas velocity measurement system for continuously monitoring releases from industrial sources. Compliant with European monitoring standards EN 16911-2 and EN 15267-3 for QAL1 and is US EPA PS-6 capable.

Unique, robust sensor and monitoring system design enables:

- Representative flue gas velocity, pressure and temperature measurement across a broad range of monitoring applications.
- Real-time normalisation of pollutant measurements to reference conditions (STP/NTP), with high quality data for emission release and mass emission reporting (kg/year).

System Configuration

System configuration options provide sensor integration flexibility.

- The PCME STACKFLOW 200 is available as a standalone sensor or as part of a monitoring system when connected to one of ENVEA's advanced control units.
- Multiple sensor lengths enable representative monitoring across a broad range of measurement locations.



TECHNOLOGY

ENVEA's innovative *ProPitot*® APF Averaging-Pitot Technology is developed from well-established measurement principles. Representative measurement is achieved from uniquely located pressure holes across the upstream and downstream edges of the sensor. Averaged differential pressure readings provide the velocity output, alongside the static pressure and temperature readings.

The automatic inlet cleaning cycle minimises blockages across the pressure holes and reduces maintenance requirements.

The standard sensor is rated up to 800°C and, with a range of sensor lengths, ensures that a comprehensive range of monitoring applications can be successfully monitored.

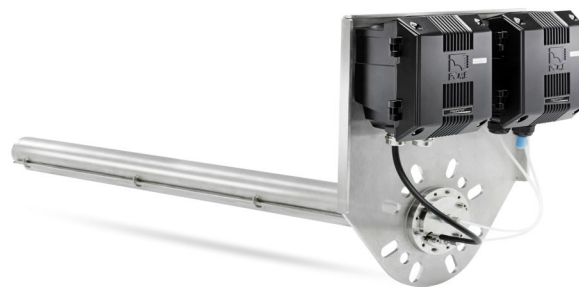

SENSOR UPGRADES

System upgrade options for demanding flue gas conditions:

- A corrosion-resistant coating is available for aggressive flue gas environments (up to 200°C) to minimise probe degradation and extend the operational performance of the sensor.
- The high-pressure back purge system is advised for high dust loading applications to maintain optimal performance.

In addition, a flue gas sampling option allows for connection to specific CEMS systems to minimise the number of stack access ports required.

Please refer to the back page for further details.

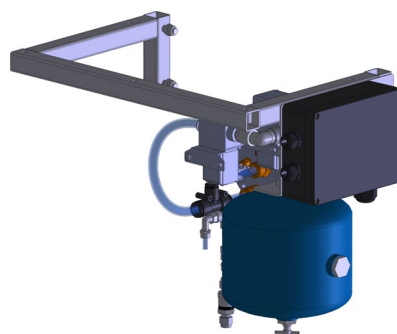

CALIBRATION AND INBUILT SELF-CHECKS

Following the Standard Reference Methods (e.g. EN ISO 16911-2) ensures that the relationship between instrument output and averaged flow across the stack is correct, enabling representative measurement to be achieved.

Manual Reference Checks

A calibration module located at the sensor heads provides quality assurance for the instrument. When connected to an external reference manometer, the zero and span (upscale) checks for the flue gas velocity and pressure measurement can be achieved.

This technique allows for the performance and linearity of the sensor to be confirmed, meeting the requirements of international standards such as EN 16911-2 and EN 14181 (QAL3).



PRODUCT FEATURES

TYPICAL APPLICATIONS

The sensor is designed to be used for process optimisation and regulatory compliance monitoring across a broad range of industrial monitoring applications:

- ✓ Waste-to-Energy and Incineration plants
- ✓ Power plants
- ✓ Iron, steel and other metals industries
- ✓ Cement and other minerals industries
- ✓ Pre and post abatement plant
- ✓ Chemical industry

SPECIFICATIONS

APPLICATION CONDITIONS

Stack Temperature	-20 to 800°C (-4°F to 1472°F) (standard sensor) -20 to 200°C (-4°F to 392°F) (coated sensor)
Stack Dust Concentration	Up to 1,000 mg/m ³ (to be tested)
Stack Diameter	0.5–8 m* (1.6–26.2 ft.)
Stack Pressure	600–1100 hPa (absolute)
Ambient Temperature	-20°C to 50°C (-4°F to 122°F)

* for larger stack diameters, please contact ENVEA

SENSOR COMMON

Probe Material	316 SS Coated probe for corrosive applications
System dimensions outside the stack (from flange)	W 350 x H 475 x D 127 mm (13.8 x 18.5 x 5.0 in.)
Enclosure Rating	IP65
Power Supply Voltage	24V DC (via a PCME Control Unit or separate power supply)
Power Consumption	Average load: 135 mA (24V) Max. load: 400 mA (24V) (during system purge)
Outputs	1x RS-485 Modbus 1x Relay output 1x 4-20mA output
Input	1x Digital input
Compressed air supply	Dry, clean (oil-free) instrument air. Pressure: 2–6 bar Max. flow rate: 20 litres/minute (1.2 m ³ /h) Average daily consumption: 0.25 m ³ (65 gal)

* for larger stack diameters, please contact ENVEA

SENSOR INSTALLATION

Installation Angle	90° to stack wall
Flange	Combined Flange suitable for 3" and 4" 150lb ANSI or DN80 PN10/PN16 or DN100 PN20
Port Internal Diameter	> 88 mm (3.5 in.)
Stack Orientation	Vertical (upwards flow only), Horizontal
Probe Insertion Length	0.6 m, 1 m, 1.5 m
Weight	From 13 kg, probe length dependent

ACCESSORY OPTIONS

Back purge recommended for dust load applications > 50 mg/m ³
PC-ME DUST TOOLS software suite
Inbuilt gas sampling port
Coated probe for corrosive applications

VELOCITY MEASUREMENT

Active Measurement Length	0.5 m up to 1.5 m
Response Time	15s
Gas Velocity Range	3–30 m/s (main Certification Range) 3–50 m/s (extended Certification Range)
Minimum Detection Velocity	3 m/s
Resolution	0.1 m/s
Lack of Fit (Linearity)	< 0.3 m/s from 2–30 m/s < 0.5 m/s above 30 m/s
Zero Drift	< 0.1 m/s per month
Span Drift	< 0.1 m/s per month

CONTROL UNITS

The Control Units are fully integrated system control and data communication hubs, with options for single and multi-sensor systems.

Designed for use with multiple sensors (total number of sensors dependent upon type)

High-speed, simultaneous data outputs: 4-20 mA, Relay (Alarm), RS-232, RS-485 (Modbus), Ethernet (Modbus TCP/IP)

Configured for use with one sensor only

Industry standard data outputs: 4-20mA, Relay (Alarm), RS-232, RS-485 (Modbus). Digital input, e.g. for plant stop signal



ProController

4-20mA and digital inputs, e.g. data from external devices and plant stop signals

Comprehensive in-built data acquisition, with full PC-ME DUST TOOLS software connectivity



Standard Controller

Expansion capabilities through network support modules

Comprehensive in-built data acquisition, with full PC-ME DUST TOOLS software connectivity

For more information regarding control unit specifications, please refer to the relevant control unit manual and the ProController Specification Guide (available on request from ENVEA).

SPECIFICATIONS

	Number of sensors/channels	1	1-32
OVERVIEW	Display	Two-tone grey, backlit graphical LCD	High-contrast, anti-glare 7" (viewable) TFT LCD
	Multiple Data Viewing	PC or RS-485	PC/RS-485/Ethernet simultaneously
	Dimensions	W220 x H123 x D80 mm	W390 x H221 x D118 mm
	Power supply voltage	100-240V AC (50/60 Hz)	85-265V AC (50/60 Hz)
	Protection Rating	IP65	IP66
	Ambient Temperature Range	-20°C to 50°C	-20°C to 50°C
	FEATURES AND FUNCTIONS	Navigation keys	Up/Down/Left/Right/Enter
Icon-driven, multilingual menus		n/a	✓
Secure password protection		✓	✓
Sensor system setup and configuration options		✓	✓
Configurable emission alarm levels		✓	✓
Sensor calibration screens		✓	✓
Seamless integration with existing PCME control units and sensors		n/a	✓
DATA LOGGING*	Long-term Log	12 months @ 15 minutes	48 months @ 15 minutes
	Short-term Log	7 days @ 1 minute	28 days @ 1 minute
	Pulse Log	8 hours @ 1 seconds	32 hours @ 1 second
	Alarm Log	500 entries	500 entries
SYSTEM OUTPUTS	Ethernet (RJ45)	n/a	✓ Connection type: 100Base-T/Tx 100 Mb/s
	USB 2.0	n/a	✓ Suitable for connecting to a local PC or laptop
	Relays	2 off (programmable)	4 off (programmable)
	4-20mA	1 off (programmable)	4 off (programmable)
	RS-485	1	1
SYSTEM INPUTS	Digital User selectable for: PLANT OFF indication, Bag-filter cleaning sequences, multiple calibrations	1	4
	4-20mA	0	2

*Data logging capacity for one sensor. Data stored varies per sensor type. Please consult ENVEA for specific data.

	STANDARD CONTROLLER	PROCONTROLLER
Analogue Output Module (AOM) provides 8 additional 4-20 mA outputs definable to sensors/channels	1	1-8
Auxiliary Input Module (AIM) provides 4 additional digital inputs, plus 4 additional relay outputs	1	1-8
Relay Output Module (ROM) provides 8 additional relay outputs	1	1-8
SPUR provides sensor network connection and local isolation during maintenance	1	1-32
Power Supply Repeater (PSR) provides voltage and signal boost for extended cable runs and large sensor networks	1	1-8

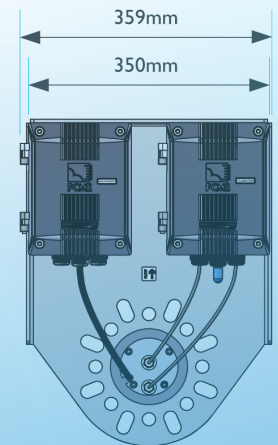
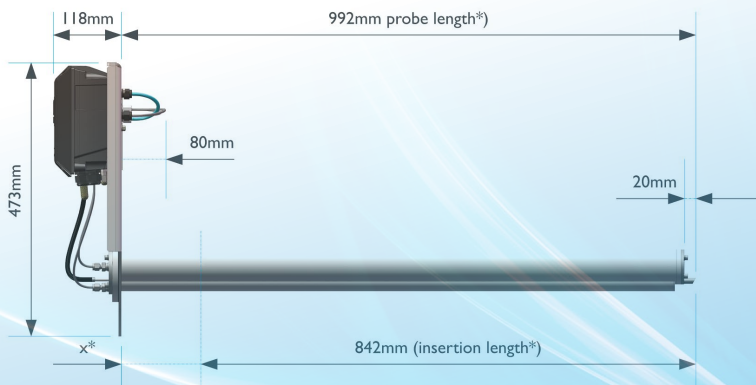

* Variable length, depending on standoff distance (x = minimum 150 mm) and probe length (example: 1 m).

ABOUT ENVEA

As a progressive environmental Company, ENVEA specialises in particulate measurement for industrial processes. With a worldwide reputation for reliability, innovation and technological excellence, the Company produces under the trademark **envea™** equipment for concentration and mass monitoring for regulatory, environmental and process control requirements. A dedicated team of qualified application and sales engineers is always on hand and should be consulted in the selection and usage of the most suitable equipment for any particulate application.



ENVEA UK
ENVEA House Rose and Crown Road
Swavesey / Cambridge - UK CB2
☎ +44 (0)1480 468200
✉ contact.gb@envea.global

