

Flue Gas Flow Measurement System

PROCESS & EMISSIONS MONITORING SYSTEMS



FLUESONIC™
INSIDE

SPECIFIC FEATURES:

- Unique extended measurement path (400mm) permits accurate and increased representative measurement
- Robust flow measurement for industrial applications
- Inbuilt automatic reference self-checks for regulatory compliance (QAL3)
- Facilitates stack velocity, volumetric flow and pollutant mass release calculations when linked to gas and dust CEMS
- Angled probe version to fit existing perpendicular ports



QAL1 Approved to EN 16911
US EPA PS-6 capable

TECHNOLOGY / APPLICATION

SYSTEM DESCRIPTION

The PCME STACKFLOW 400 is an advanced flue gas flow measurement system for continuously monitoring releases from industrial sources. This instrument complies with European monitoring standards EN16911-2 and 15267-3 for QAL1.

The PCME STACKFLOW 400 sensor satisfies the need for high quality assurance on emission release data, reporting mass emissions (kg/year) as well as concentration monitoring.

It uses ENVEA's unique *Fluesonic*[®] technology and mathematical measurement algorithm (patent pending) that allows the transit time of the signal to be measured accurately in real stack conditions, hence permitting:

- An extended measurement path of 400mm in a single, stack-mounted probe design
- Capability to deal with flow profiles across the extended measurement path
- Tolerance to contamination and flow eddies



© Lühr Filter, Biomass Combustion plant. Reproduced with kind permission.

PRINCIPLE OF OPERATION

The instrument uses ENVEA's innovative *FlueSonic*[®] Ultrasonic Technology, measuring the time of flight of ultrasonic signals between two transducers (see Figure 1). Each transducer emits an ultrasonic pulse that is detected by the other. The sensor is mounted in the stack at an angle (typically 45 degrees), such that the transducers lie upstream and downstream of each other.

The time of flight of an ultrasonic pulse travelling between the two transducers depends on the distance it has to travel, the speed of sound in the gas and the velocity of the gas. The time of flight of a pulse travelling in the same direction as the gas (downstream) is shorter than the time of flight of the pulse travelling against the direction of the flow (upstream).

The difference in these flight times is directly proportional to the velocity of the flue gas.

The stack flow velocity in the measurement path is calculated from the upstream and downstream transit time in a way that is independent of the speed of sound in the gas, flue gas temperature or pressure of flue gas composition. The flow rate is calculated by multiplication of average flue gas velocity by the stack cross-section area.

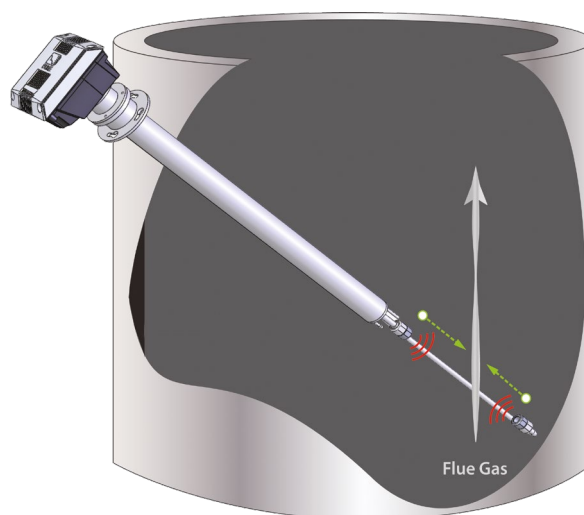

Figure 1: Principle of Operation of the PCME STACKFLOW 400

CALIBRATION AND INBUILT SELF-CHECKS

The PCME STACKFLOW 400 measures the average velocity in the stack across a measurement path length of 400mm. It is important to locate this measurement path in a representative location across the stack flow profile and as such the instrument is provided with a 900mm extension tube with movable flange so that the measurement path can be located in the optimum position (probe insertion length: approx. 1.4 m), see Figure 2.

As with all flow measurement devices, the relationship between instrument output and average flow across the full cross-sectional area of the stack is calibrated by comparison to measurements made using a Standard Reference Method (such as Pitot traverses or tracer methods pursuant to EN ISO 16911-2).

Automated Reference Checks

The PCME STACKFLOW 400 performs Lower and Upper Reference (Zero and Span) sensor self-checks (a requirement of EN16911-2), see Figure 3.

These self-checks assess not only the performance of the electronics and measurement algorithm, but also the performance and correct operation of the transducers, including their ability to transmit, receive and discriminate actual ultrasonic signals from noise and offsets in the stack environment.

These automatic Quality Assurance features provide outputs which can be used for QAL3 reporting requirements (as defined in EN ISO 16911-2) and provide feedback to the user on the correct operation of the instrument.

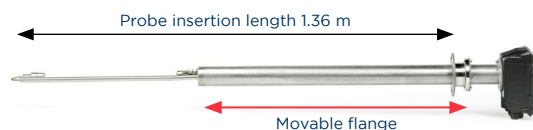

Figure 2: PCME STACKFLOW 400 sensor with movable flange to locate the optimum measurement path



Figure 3: PCME STACKFLOW 400 Lower and Upper Reference Self-Checks

PRODUCT FEATURES

TYPICAL APPLICATIONS

The PCME STACKFLOW 400 is suitable for measuring the flue gas flow rate after both bag-filter and electrostatic precipitator (ESP) arrestment plant and satisfies the need for high quality measurement on emission release data. From a regulatory perspective its high quality assurance features make the sensor suitable as a compliance device.

Typical application areas are:

- Waste-to-Energy and Incineration plants
- Emissions from Steel, Chemical and Mineral processing applications
- Gas Turbines and Coal-fired Power plants
- Industrial stacks (before or after final arrestment plant)



© Lühr Filter. Integrated Steel plant. Reproduced with kind permission.

ADDED VALUE FEATURES AND BENEFITS

| APPLICATION CONDITIONS | SPECIFICATION |
|------------------------|--------------------------------|
| Stack Temperature | -20°C to 200°C (-4°F to 392°F) |
| Stack Diameter | ≥0.5 m (1.6 ft) |
| Stack Pressure | ±100 mbar |
| Ambient Temperature* | -20°C to 50°C (-4°F to 122°F) |

*at monitoring point

| MEASUREMENT SPECIFICATIONS | |
|----------------------------|---|
| Measurement Path | 400 mm (16", nom.) |
| Response Time | 40 s |
| Gas Velocity | ±(0-50) m/s ±(0-30) m/s (Certification Range) Resolution: 0.1 m/s |
| Minimum Detection Velocity | 0.0 m/s |

| SENSOR COMMON SPECIFICATIONS | |
|------------------------------|---|
| Sensor Material | Sensor body: 316 SS, Transducers: Hastelloy* |
| Enclosure Dimensions | W 148 x H 192 x D 106 mm (5.8 x 7.6 x 4.2 in.) |
| Enclosure Rating | IP65 |
| Power Supply Voltage | 24V DC (via the control unit or PSR) |
| Current Consumption | Average load: 120mA (24V), max. load: 140mA (24V) |
| Outputs | 1x RS-485 Modbus, 2x Relays, 1x 4-20mA |
| Input | 1x Digital Input |
| Flange | 3"/4" ASME // DN80/100 PN10/16 (combined flange), also DN40 PN6 |

| STRAIGHT SENSOR | |
|--------------------|--|
| Installation Angle | 45° to stack wall |
| Sensor Options | Horizontal stack orientation Vertical stack orientation |
| Insertion Length | max. 1360 mm (53.5") |
| Weight | 8.6 kg (19 lb) |

| ANGLED SENSOR | |
|--------------------|--|
| Installation Angle | 90° to stack wall |
| Flange | Option: 4" BSP Adaptor |
| Sensor Options | Horizontal stack orientation Vertical stack orientation |
| Insertion Length | max. 805 mm (32", nom.) |
| Weight | 6.2 kg (13.5 lb) |

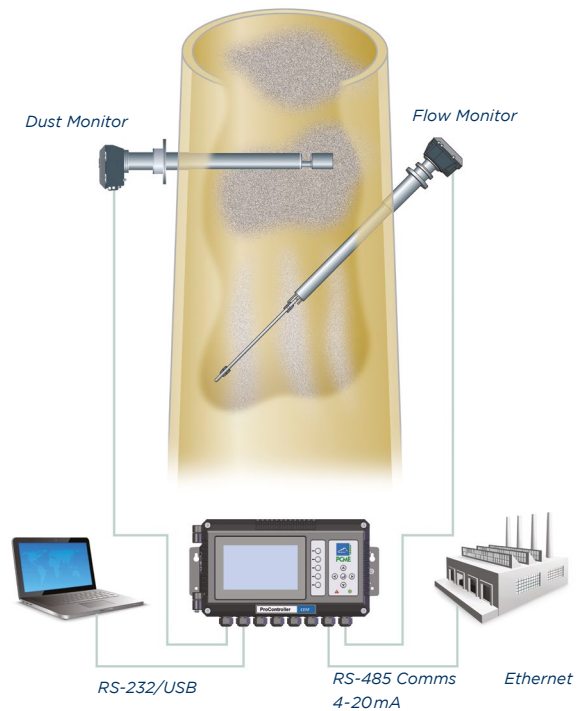
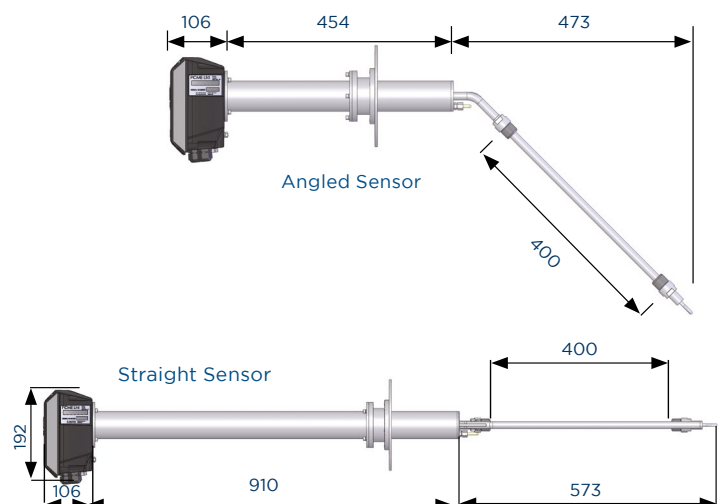

Figure 4: PCME STACKFLOW 400 combined with a PCME dust monitor for integrated concentration and mass emissions reporting



| NETWORK CONTROLLERS AND ACCESSORIES | | | |
|-------------------------------------|--|--------------------------------------|---|
| OVERVIEW | Number of sensors/channels | 1 | 1-32 |
| | Display | Two-tone grey, backlit graphical LCD | High-contrast, anti-glare 7" (viewable) TFT LCD |
| | Multiple Data Viewing | PC or RS-485 | PC/RS-485/Ethernet simultaneously |
| | Dimensions | W220 x H124 x D80 mm | W390 x H221 x D118 mm |
| | Power supply voltage | 100-240V AC (50/60 Hz) | 85-265V AC (50/60 Hz) |
| | Protection Rating | IP65 | IP66 |
| | Ambient Temperature Range | -20°C to 50°C | -20°C to 50°C |
| FEATURES AND FUNCTIONS | Navigation keys | Up/Down/Left/Right/ENTER | Up/Down/Left/Right/ENTER plus 5 function keys: 3x short-cut keys and 2 user-programmable keys |
| | Icon-driven, multilingual menus | n/a | ✓ |
| | Secure password protection | ✓ | ✓ |
| | Sensor system setup and configuration options | ✓ | ✓ |
| | Configurable emission alarm levels | ✓ | ✓ |
| | Sensor calibration screens | ✓ | ✓ |
| | Seamless integration with existing PCME control units and sensors | n/a | ✓ |
| DATA LOGGING* | Long-term Log | 12 months @ 15 minutes | 48 months @ 15 minutes |
| | Short-term Log | 7 days @ 1 minute | 28 days @ 1 minute |
| | Pulse Log | 8 hours @ 1 seconds | 32 hours @ 1 second |
| | Alarm Log | 500 entries | 500 entries |
| SYSTEM OUTPUTS | Ethernet (RJ45) | n/a | ✓ Connection type: 100Base-T/Tx 100 Mb/s |
| | USB 2.0 | n/a | ✓ Suitable for connecting to a local PC or laptop |
| | Relays | 2 off (programmable) | 4 off (programmable) |
| | 4-20mA | 1 off (programmable) | 4 off (programmable) |
| | RS-485 | 1 | 1 |
| SYSTEM INPUTS | Digital User selectable for: PLANT OFF indication, Bag-filter cleaning sequences, multiple calibrations | 1 | 4 |
| | 4-20mA | 0 | 2 |

*Data logging capacity for one sensor. Data stored varies per sensor type. Please consult ENVEA for specific data.

| | | | |
|--|---|---|------|
| Network Modules (can be connected to Controller Network systems to provide additional Inputs and Outputs) | Analogue Output Module (AOM) provides 8 additional 4-20 mA outputs definable to sensors/channels | 1 | 1-8 |
| | Auxiliary Input Module (AIM) provides 4 additional digital inputs, plus 4 additional relay outputs | 1 | 1-8 |
| | Relay Output Module (ROM) provides 8 additional relay outputs | 1 | 1-8 |
| | SPUR provides sensor network connection and local isolation during maintenance | 1 | 1-32 |
| | Power Supply Repeater (PSR) provides voltage and signal boost for extended cable runs and large sensor networks | 1 | 1-8 |

ABOUT ENVEA

As a progressive environmental Company, ENVEA specialises in particulate measurement for industrial processes. With a worldwide reputation for reliability, innovation and technological excellence, the Company produces under the trademark **envea**™ equipment for concentration and mass monitoring for regulatory, environmental and process control requirements. A dedicated team of qualified application and sales engineers is always on hand and should be consulted in the selection and usage of the most suitable equipment for any particulate application.



ENVEA UK
ENVEA House Rose and Crown Road
Swavesey / Cambridge - UK CB24 4RB
+44 (0)1480 468200
contact.gb@envea.global

